



# Processing Devices



For single and double sided tapes, as well for labels and die-cut



VOLZ® TAPES is your specialist in self-adhesive technology and deliver all types of technical **self- adhesive tapes, die-cuts, packing-materials and processing devices.**

In our highly contemporary machinery we slitting, slitting rewinding, cutting, lasering cutting, spooling and laminating exactly according to the customers 'request. It is our aim to solve the customer's request, effective, cost-oriented and process-safe.

The result: Adhesive solution in standard- and special dimension for all areas of application. Moreover, you can receive the appropriate packing-materials and processing devices that facilitate your work processes.

VOLZ® TAPES is not only DIN ISO EN 9001:2015 certified but is also UL certified re-packer, thus fulfilling the GS1 standards by participating in the global GS1-System. We have furthermore a completely equipped lab in which we conduct all required tests such as the adhesive peel of 90° & 180°, tensile strength, ultimate elongation, shear strength, rolling ball tack, loop tack and thickness test.

We are a member of Afera ([www.afera.com](http://www.afera.com)) and conduct our tests be this norm. We are of course in the position to also conduct tests of other norms.

Since 2014 we develop and produce double sided adhesive tapes. Do you need large jumbos, small jumbos, log rolls or other cut rolls, spools, plan rolls in neutral or own packaging? VOLZ® TAPES will deliver the matching solution!

We would like to point out that we will be your versatile partner in the professional self-adhesive technology and therefore we will develop us constantly.

## Processing devices simplifies your production processes

On the following pages, you will find an overview about our processing devices.

You will find all information about our hand dispenser, bench dispenser, automatic tape dispenser, label and die-cut dispenser and useful accessories.

Processing devices handle fast and accurate single- and double sided tapes, labels and die-cuts. Thus, you save time and costs for your production processes.

Of course, you can receive matching spare parts and services for each individual product.

If the desired product is not part of the list or do you have any questions, do not hesitate to contact us.

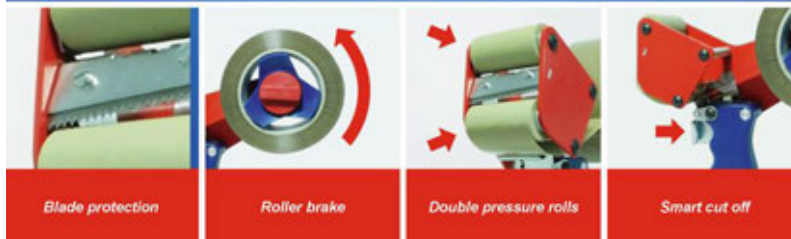
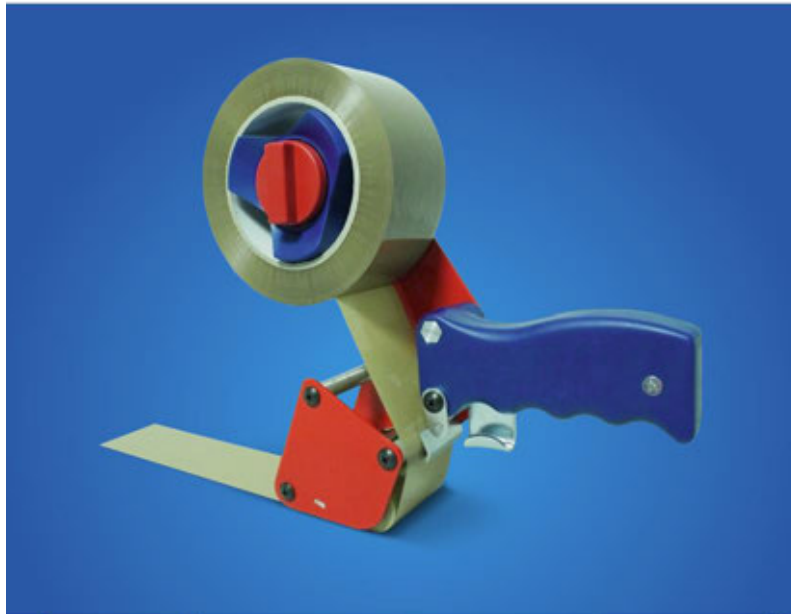
**PACK** PROFI 161-21402  
*Manual tape dispenser*









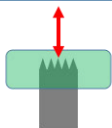
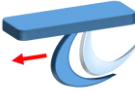

This professional manual device in new wrapping is the well tested 161-21402. We succeeded in negotiating and concluding a world-wide exclusive contract with the manufacturer of this device. Moreover, VOLZ® TAPES has now the world-wide exclusive distributing rights for this article since 01.02.2013. Due to the fact that the product is intended to be marketed by numerous customers, we maintain a neutral packaging.

This professional manual tape dispenser is used for the sealing of cartons and packages. With its roller brake it is especially suitable for an easy tape dispensing. Two contact pressure allow an especially simple and smooth tape application. The tape cut-off is implemented by activating the release inside the handle, thus protecting the user from injuries.



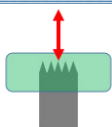
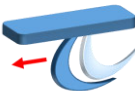



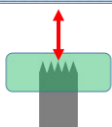
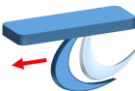

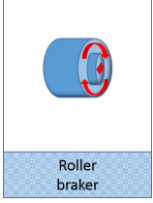

We have installed a special website for this product. More information regarding this article under: [www.tapedispenser.de](http://www.tapedispenser.de)

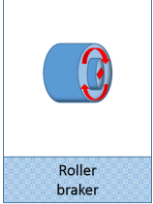

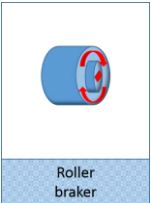
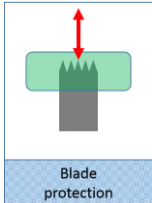
## Profi manual tape dispenser

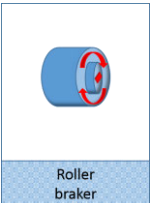
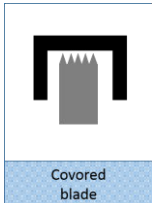
Article	Product picture	Technical data	Features															
<b>161-21401</b> <ul style="list-style-type: none"> <li>🔗 Professional manual tape dispenser for packaging tapes</li> <li>🔗 Tension control adjustable by hand</li> <li>🔗 Two contact pressure allow an especially simple and smooth tape application</li> <li>🔗 Hidden blade (blade protection)</li> <li>🔗 The tape cut-off is implemented by activating the release inside the handle</li> </ul>		<table border="1"> <tr> <td><b>Weight</b></td> <td>410 g</td> </tr> <tr> <td><b>Length/Width/Height</b></td> <td>205/40/210 mm</td> </tr> <tr> <td><b>Roll Diameter</b></td> <td>170 mm</td> </tr> <tr> <td><b>Roll Width</b></td> <td>25 mm</td> </tr> <tr> <td><b>Roll core</b></td> <td>3 inch = 76 mm</td> </tr> <tr> <td><b>Preset length adjustable</b></td> <td>Impossible</td> </tr> <tr> <td><b>Adhesive tape type</b></td> <td>Single sided</td> </tr> </table>	<b>Weight</b>	410 g	<b>Length/Width/Height</b>	205/40/210 mm	<b>Roll Diameter</b>	170 mm	<b>Roll Width</b>	25 mm	<b>Roll core</b>	3 inch = 76 mm	<b>Preset length adjustable</b>	Impossible	<b>Adhesive tape type</b>	Single sided	 Roller braker	 Double pressure rolls
<b>Weight</b>	410 g																	
<b>Length/Width/Height</b>	205/40/210 mm																	
<b>Roll Diameter</b>	170 mm																	
<b>Roll Width</b>	25 mm																	
<b>Roll core</b>	3 inch = 76 mm																	
<b>Preset length adjustable</b>	Impossible																	
<b>Adhesive tape type</b>	Single sided																	
			 Blade protection	 Smart Cut off														
<b>161-21402</b> <ul style="list-style-type: none"> <li>🔗 Professional manual tape dispenser for packaging tapes</li> <li>🔗 Tension control adjustable by hand</li> <li>🔗 Two contact pressure allow an especially simple and smooth tape application</li> <li>🔗 Hidden blade (blade protection)</li> <li>🔗 The tape cut-off is implemented by activating the release inside the handle</li> </ul>		<table border="1"> <tr> <td><b>Weight</b></td> <td>520 g</td> </tr> <tr> <td><b>Length/Width/Height</b></td> <td>220/65/210 mm</td> </tr> <tr> <td><b>Roll Diameter</b></td> <td>170 mm</td> </tr> <tr> <td><b>Roll Width</b></td> <td>50 mm</td> </tr> <tr> <td><b>Roll core</b></td> <td>3 inch = 76 mm</td> </tr> <tr> <td><b>Preset length adjustable</b></td> <td>Impossible</td> </tr> <tr> <td><b>Adhesive tape type</b></td> <td>Single sided</td> </tr> </table>	<b>Weight</b>	520 g	<b>Length/Width/Height</b>	220/65/210 mm	<b>Roll Diameter</b>	170 mm	<b>Roll Width</b>	50 mm	<b>Roll core</b>	3 inch = 76 mm	<b>Preset length adjustable</b>	Impossible	<b>Adhesive tape type</b>	Single sided	 Roller braker	 Double pressure rolls
<b>Weight</b>	520 g																	
<b>Length/Width/Height</b>	220/65/210 mm																	
<b>Roll Diameter</b>	170 mm																	
<b>Roll Width</b>	50 mm																	
<b>Roll core</b>	3 inch = 76 mm																	
<b>Preset length adjustable</b>	Impossible																	
<b>Adhesive tape type</b>	Single sided																	
			 Blade protection	 Smart Cut off														
<b>161-21403</b> <ul style="list-style-type: none"> <li>🔗 Professional manual tape dispenser for packaging tapes</li> <li>🔗 Tension control adjustable by hand</li> <li>🔗 Two contact pressure allow an especially simple and smooth tape application</li> <li>🔗 Hidden blade (blade protection)</li> <li>🔗 The tape cut-off is implemented by activating the release inside the handle</li> </ul>		<table border="1"> <tr> <td><b>Weight</b></td> <td>700 g</td> </tr> <tr> <td><b>Length/Width/Height</b></td> <td>215/90/210 mm</td> </tr> <tr> <td><b>Roll Diameter</b></td> <td>170 mm</td> </tr> <tr> <td><b>Roll Width</b></td> <td>75 mm</td> </tr> <tr> <td><b>Roll core</b></td> <td>3 inch = 76 mm</td> </tr> <tr> <td><b>Preset length adjustable</b></td> <td>Impossible</td> </tr> <tr> <td><b>Adhesive tape type</b></td> <td>Single sided</td> </tr> </table>	<b>Weight</b>	700 g	<b>Length/Width/Height</b>	215/90/210 mm	<b>Roll Diameter</b>	170 mm	<b>Roll Width</b>	75 mm	<b>Roll core</b>	3 inch = 76 mm	<b>Preset length adjustable</b>	Impossible	<b>Adhesive tape type</b>	Single sided	 Roller braker	 Double pressure rolls
<b>Weight</b>	700 g																	
<b>Length/Width/Height</b>	215/90/210 mm																	
<b>Roll Diameter</b>	170 mm																	
<b>Roll Width</b>	75 mm																	
<b>Roll core</b>	3 inch = 76 mm																	
<b>Preset length adjustable</b>	Impossible																	
<b>Adhesive tape type</b>	Single sided																	
			 Blade protection	 Smart Cut off														

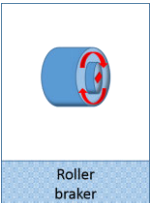
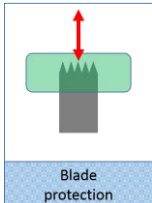

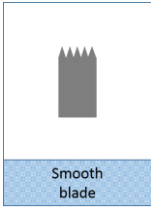

## Classic hand dispenser

Article	Product picture	Technical data	Features														
<b>505008</b> <ul style="list-style-type: none"> <li>Hand dispenser for packaging tapes</li> <li>Tension control adjustable by hand</li> </ul>		<table border="1"> <tr><td>Weight</td><td>625 g</td></tr> <tr><td>Length/Width/Height</td><td>180/70/250 mm</td></tr> <tr><td>Roll Diameter</td><td>136 mm</td></tr> <tr><td>Roll Width</td><td>50 mm</td></tr> <tr><td>Roll core</td><td>3 inch = 76 mm</td></tr> <tr><td>Preset length adjustable</td><td>Impossible</td></tr> <tr><td>Adhesive tape type</td><td>Single sided</td></tr> </table>	Weight	625 g	Length/Width/Height	180/70/250 mm	Roll Diameter	136 mm	Roll Width	50 mm	Roll core	3 inch = 76 mm	Preset length adjustable	Impossible	Adhesive tape type	Single sided	 <p>Roller braker</p>
Weight	625 g																
Length/Width/Height	180/70/250 mm																
Roll Diameter	136 mm																
Roll Width	50 mm																
Roll core	3 inch = 76 mm																
Preset length adjustable	Impossible																
Adhesive tape type	Single sided																
<b>505009</b> <ul style="list-style-type: none"> <li>Hand dispenser for packaging tapes</li> <li>Tension control adjustable by hand</li> </ul>		<table border="1"> <tr><td>Weight</td><td>785 g</td></tr> <tr><td>Length/Width/Height</td><td>180/100/250 mm</td></tr> <tr><td>Roll Diameter</td><td>136 mm</td></tr> <tr><td>Roll Width</td><td>75 mm</td></tr> <tr><td>Roll core</td><td>3 inch = 76 mm</td></tr> <tr><td>Preset length adjustable</td><td>Impossible</td></tr> <tr><td>Adhesive tape type</td><td>Single sided</td></tr> </table>	Weight	785 g	Length/Width/Height	180/100/250 mm	Roll Diameter	136 mm	Roll Width	75 mm	Roll core	3 inch = 76 mm	Preset length adjustable	Impossible	Adhesive tape type	Single sided	 <p>Roller braker</p>
Weight	785 g																
Length/Width/Height	180/100/250 mm																
Roll Diameter	136 mm																
Roll Width	75 mm																
Roll core	3 inch = 76 mm																
Preset length adjustable	Impossible																
Adhesive tape type	Single sided																
<b>161-4200</b> <ul style="list-style-type: none"> <li>Hand dispenser for packaging tapes</li> <li>Tension control adjustable by hand</li> <li>Hidden blade (blade protection)</li> <li>Soft gummed handle for a comfortable, secure grip</li> </ul>		<table border="1"> <tr><td>Weight</td><td>500 g</td></tr> <tr><td>Length/Width/Height</td><td>180/60/230 mm</td></tr> <tr><td>Roll Diameter</td><td>140 mm</td></tr> <tr><td>Roll Width</td><td>50 mm</td></tr> <tr><td>Roll core</td><td>3 inch = 76 mm</td></tr> <tr><td>Preset length adjustable</td><td>Impossible</td></tr> <tr><td>Adhesive tape type</td><td>Single sided</td></tr> </table>	Weight	500 g	Length/Width/Height	180/60/230 mm	Roll Diameter	140 mm	Roll Width	50 mm	Roll core	3 inch = 76 mm	Preset length adjustable	Impossible	Adhesive tape type	Single sided	 <p>Roller braker</p>  <p>Blade protection</p>  <p>Comfortable grip</p>
Weight	500 g																
Length/Width/Height	180/60/230 mm																
Roll Diameter	140 mm																
Roll Width	50 mm																
Roll core	3 inch = 76 mm																
Preset length adjustable	Impossible																
Adhesive tape type	Single sided																
<b>tesa®6300</b> <ul style="list-style-type: none"> <li>tesa hand dispenser for packaging tapes</li> <li>tension control adjustable by hand</li> <li>covered blade</li> </ul>		<table border="1"> <tr><td>Weight</td><td>350 g</td></tr> <tr><td>Length/Width/Height</td><td>150/65/240 mm</td></tr> <tr><td>Roll Diameter</td><td>120 mm</td></tr> <tr><td>Roll Width</td><td>50 mm</td></tr> <tr><td>Roll core</td><td>3 inch = 76 mm</td></tr> <tr><td>Preset length adjustable</td><td>Impossible</td></tr> <tr><td>Adhesive tape type</td><td>Single sided</td></tr> </table>	Weight	350 g	Length/Width/Height	150/65/240 mm	Roll Diameter	120 mm	Roll Width	50 mm	Roll core	3 inch = 76 mm	Preset length adjustable	Impossible	Adhesive tape type	Single sided	 <p>Roller braker</p>  <p>Covered blade</p>
Weight	350 g																
Length/Width/Height	150/65/240 mm																
Roll Diameter	120 mm																
Roll Width	50 mm																
Roll core	3 inch = 76 mm																
Preset length adjustable	Impossible																
Adhesive tape type	Single sided																
<b>tesa®6400</b> <ul style="list-style-type: none"> <li>Professional tesa hand dispenser for packaging tapes</li> <li>Tension control adjustable by hand</li> <li>Hidden blade (injury protection)</li> <li>Soft gummed handle for a comfortable, secure grip</li> </ul>		<table border="1"> <tr><td>Weight</td><td>500 g</td></tr> <tr><td>Length/Width/Height</td><td>220/60/220 mm</td></tr> <tr><td>Roll Diameter</td><td>140 mm</td></tr> <tr><td>Roll Width</td><td>50 mm</td></tr> <tr><td>Roll core</td><td>3 inch = 76 mm</td></tr> <tr><td>Preset length adjustable</td><td>Impossible</td></tr> <tr><td>Adhesive tape type</td><td>Single sided</td></tr> </table>	Weight	500 g	Length/Width/Height	220/60/220 mm	Roll Diameter	140 mm	Roll Width	50 mm	Roll core	3 inch = 76 mm	Preset length adjustable	Impossible	Adhesive tape type	Single sided	 <p>Roller braker</p>  <p>Blade protection</p>  <p>Comfortable grip</p>
Weight	500 g																
Length/Width/Height	220/60/220 mm																
Roll Diameter	140 mm																
Roll Width	50 mm																
Roll core	3 inch = 76 mm																
Preset length adjustable	Impossible																
Adhesive tape type	Single sided																

## Special hand dispenser

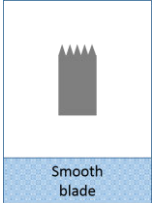
Article	Product picture	Technical data	Features														
<b>161-0213</b> <ul style="list-style-type: none"> <li>Hand dispenser for double sided tapes</li> <li>The release tape will be coiled</li> <li>Adjustable brake, stop trigger cuts the tape</li> </ul>		<table border="1"> <tr><td>Weight</td><td>330 g</td></tr> <tr><td>Length/Width/Height</td><td>150/25/210 mm</td></tr> <tr><td>Roll Diameter</td><td>150 mm</td></tr> <tr><td>Roll Width</td><td>25 mm</td></tr> <tr><td>Roll core</td><td>3 inch = 76 mm</td></tr> <tr><td>Preset length adjustable</td><td>Impossible</td></tr> <tr><td>Adhesive tape type</td><td>Double sided</td></tr> </table>	Weight	330 g	Length/Width/Height	150/25/210 mm	Roll Diameter	150 mm	Roll Width	25 mm	Roll core	3 inch = 76 mm	Preset length adjustable	Impossible	Adhesive tape type	Double sided	 
Weight	330 g																
Length/Width/Height	150/25/210 mm																
Roll Diameter	150 mm																
Roll Width	25 mm																
Roll core	3 inch = 76 mm																
Preset length adjustable	Impossible																
Adhesive tape type	Double sided																
<b>tesa® 6032</b> <ul style="list-style-type: none"> <li>Special hand dispenser for filament and strapping tapes</li> <li>Special blade to cut filament reinforced packaging tapes</li> </ul>		<table border="1"> <tr><td>Weight</td><td>335 g</td></tr> <tr><td>Length/Width/Height</td><td>220/45/80 mm</td></tr> <tr><td>Roll Diameter</td><td>150 mm</td></tr> <tr><td>Roll Width</td><td>25 mm</td></tr> <tr><td>Roll core</td><td>3 inch = 76 mm</td></tr> <tr><td>Preset length adjustable</td><td>Impossible</td></tr> <tr><td>Adhesive tape type</td><td>Single sided</td></tr> </table>	Weight	335 g	Length/Width/Height	220/45/80 mm	Roll Diameter	150 mm	Roll Width	25 mm	Roll core	3 inch = 76 mm	Preset length adjustable	Impossible	Adhesive tape type	Single sided	
Weight	335 g																
Length/Width/Height	220/45/80 mm																
Roll Diameter	150 mm																
Roll Width	25 mm																
Roll core	3 inch = 76 mm																
Preset length adjustable	Impossible																
Adhesive tape type	Single sided																
<b>tesa® 6076</b> <ul style="list-style-type: none"> <li>Special hand dispenser with robust metal housing for packaging tapes</li> </ul>		<table border="1"> <tr><td>Weight</td><td>500 g</td></tr> <tr><td>Length/Width/Height</td><td>165/60/130 mm</td></tr> <tr><td>Roll Diameter</td><td>120 mm</td></tr> <tr><td>Roll Width</td><td>50 mm</td></tr> <tr><td>Roll core</td><td>3 inch = 76 mm</td></tr> <tr><td>Preset length adjustable</td><td>Impossible</td></tr> <tr><td>Adhesive tape type</td><td>Single sided</td></tr> </table>	Weight	500 g	Length/Width/Height	165/60/130 mm	Roll Diameter	120 mm	Roll Width	50 mm	Roll core	3 inch = 76 mm	Preset length adjustable	Impossible	Adhesive tape type	Single sided	
Weight	500 g																
Length/Width/Height	165/60/130 mm																
Roll Diameter	120 mm																
Roll Width	50 mm																
Roll core	3 inch = 76 mm																
Preset length adjustable	Impossible																
Adhesive tape type	Single sided																
<b>161-0270-50</b> <ul style="list-style-type: none"> <li>Special hand dispenser with robust metal housing for packaging tapes</li> <li>Identically constructed dispenser for tapes in:  19mm Width: 161-0270-19  25mm Width: 161-0270-25  30mm Width: 161-0270-30  38mm Width: 161-0270-38</li> </ul>		<table border="1"> <tr><td>Weight</td><td>480 g</td></tr> <tr><td>Length/Width/Height</td><td>165/55/125 mm</td></tr> <tr><td>Roll Diameter</td><td>110 mm</td></tr> <tr><td>Roll Width</td><td>50 mm</td></tr> <tr><td>Roll core</td><td>3 inch = 76 mm</td></tr> <tr><td>Preset length adjustable</td><td>Impossible</td></tr> <tr><td>Adhesive tape type</td><td>Single sided</td></tr> </table>	Weight	480 g	Length/Width/Height	165/55/125 mm	Roll Diameter	110 mm	Roll Width	50 mm	Roll core	3 inch = 76 mm	Preset length adjustable	Impossible	Adhesive tape type	Single sided	
Weight	480 g																
Length/Width/Height	165/55/125 mm																
Roll Diameter	110 mm																
Roll Width	50 mm																
Roll core	3 inch = 76 mm																
Preset length adjustable	Impossible																
Adhesive tape type	Single sided																

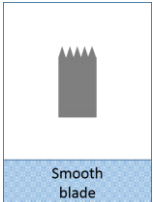

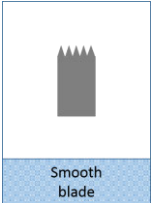
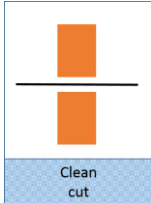

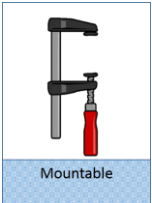
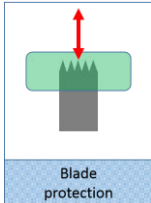
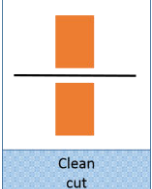

## Classic bench dispenser

Article	Product picture	Technical data	Features														
<b>161-0257</b> <ul style="list-style-type: none"> <li>Bench dispenser for processing tapes</li> <li>For 1"-core or also 3"-core</li> <li>Non-slip</li> </ul>		<table border="1"> <tr><td>Weight</td><td>1280 g</td></tr> <tr><td>Length/Width/Height</td><td>220/79/90 mm</td></tr> <tr><td>Roll Diameter</td><td>110 mm</td></tr> <tr><td>Roll Width</td><td>25 mm</td></tr> <tr><td>Roll core</td><td>1,5 or 3 inch</td></tr> <tr><td>Preset length adjustable</td><td>Impossible</td></tr> <tr><td>Adhesive tape type</td><td>Single sided</td></tr> </table>	Weight	1280 g	Length/Width/Height	220/79/90 mm	Roll Diameter	110 mm	Roll Width	25 mm	Roll core	1,5 or 3 inch	Preset length adjustable	Impossible	Adhesive tape type	Single sided	 <p>Smooth blade</p>
Weight	1280 g																
Length/Width/Height	220/79/90 mm																
Roll Diameter	110 mm																
Roll Width	25 mm																
Roll core	1,5 or 3 inch																
Preset length adjustable	Impossible																
Adhesive tape type	Single sided																
<b>tesa®57422</b> <ul style="list-style-type: none"> <li>Bench dispenser for processing tapes</li> <li>Non-slip base, sturdy case</li> <li>Serrated blade for a clean, convenient cut</li> </ul>		<table border="1"> <tr><td>Weight</td><td>2000 g</td></tr> <tr><td>Length/Width/Height</td><td>230/70/130 mm</td></tr> <tr><td>Roll Diameter</td><td>110 mm</td></tr> <tr><td>Roll Width</td><td>25 mm</td></tr> <tr><td>Roll core</td><td>3 inch = 76 mm</td></tr> <tr><td>Preset length adjustable</td><td>Impossible</td></tr> <tr><td>Adhesive tape type</td><td>Single sided</td></tr> </table>	Weight	2000 g	Length/Width/Height	230/70/130 mm	Roll Diameter	110 mm	Roll Width	25 mm	Roll core	3 inch = 76 mm	Preset length adjustable	Impossible	Adhesive tape type	Single sided	 <p>Smooth blade</p>
Weight	2000 g																
Length/Width/Height	230/70/130 mm																
Roll Diameter	110 mm																
Roll Width	25 mm																
Roll core	3 inch = 76 mm																
Preset length adjustable	Impossible																
Adhesive tape type	Single sided																
<b>tesa®6090</b> <ul style="list-style-type: none"> <li>Robust bench dispenser with steel case for strapping and packaging tapes</li> <li>For up to two rolls</li> <li>Separate blade for each roll</li> </ul>		<table border="1"> <tr><td>Weight</td><td>2500 g</td></tr> <tr><td>Length/Width/Height</td><td>270/70/125 mm</td></tr> <tr><td>Roll Diameter</td><td>125 mm</td></tr> <tr><td>Roll Width</td><td>2 x 25 mm</td></tr> <tr><td>Roll core</td><td>3 inch = 76 mm</td></tr> <tr><td>Preset length adjustable</td><td>Impossible</td></tr> <tr><td>Adhesive tape type</td><td>Single sided</td></tr> </table>	Weight	2500 g	Length/Width/Height	270/70/125 mm	Roll Diameter	125 mm	Roll Width	2 x 25 mm	Roll core	3 inch = 76 mm	Preset length adjustable	Impossible	Adhesive tape type	Single sided	 <p>Smooth blade</p>  <p>Clean cut</p>
Weight	2500 g																
Length/Width/Height	270/70/125 mm																
Roll Diameter	125 mm																
Roll Width	2 x 25 mm																
Roll core	3 inch = 76 mm																
Preset length adjustable	Impossible																
Adhesive tape type	Single sided																

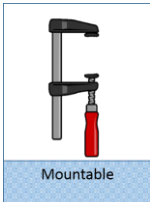
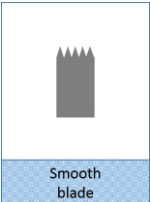

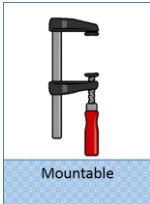
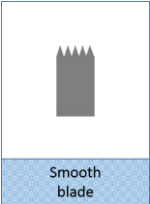

## Special bench dispenser

Article	Product picture	Technical data	Features														
<b>161-6080</b> <ul style="list-style-type: none"> <li>Special purpose bench dispenser for diverse adhesive tapes</li> <li>Screw clamp allows flexible fastening of the dispenser, for example on desk edges</li> </ul>		<table border="1"> <tr><td>Weight</td><td>3200 g</td></tr> <tr><td>Length/Width/Height</td><td>260/320/210 mm</td></tr> <tr><td>Roll Diameter</td><td>140 mm</td></tr> <tr><td>Roll Width</td><td>1 roll: 100 mm 2 rolls: 2 x 50 mm</td></tr> <tr><td>Roll core</td><td>3 inch = 76 mm</td></tr> <tr><td>Preset length adjustable</td><td>Impossible</td></tr> <tr><td>Adhesive tape type</td><td>Single sided</td></tr> </table>	Weight	3200 g	Length/Width/Height	260/320/210 mm	Roll Diameter	140 mm	Roll Width	1 roll: 100 mm 2 rolls: 2 x 50 mm	Roll core	3 inch = 76 mm	Preset length adjustable	Impossible	Adhesive tape type	Single sided	 <p>Mountable</p>  <p>Blade protection</p>  <p>Clean cut</p>
Weight	3200 g																
Length/Width/Height	260/320/210 mm																
Roll Diameter	140 mm																
Roll Width	1 roll: 100 mm 2 rolls: 2 x 50 mm																
Roll core	3 inch = 76 mm																
Preset length adjustable	Impossible																
Adhesive tape type	Single sided																

## Special bench dispenser



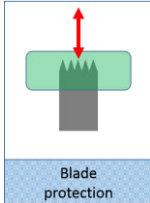

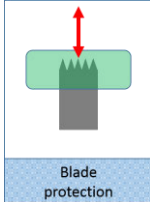
Article	Product picture	Technical data	Features														
<b>tesa®6009</b> <ul style="list-style-type: none"> <li>Special purpose bench dispenser for packaging and masking tapes</li> <li>Screw clamp allows flexible fastening of the dispenser, for example on desk edges</li> </ul>		<table border="1"> <tr><td>Weight</td><td>340 g</td></tr> <tr><td>Length/Width/Height</td><td>180/85/230 mm</td></tr> <tr><td>Roll Diameter</td><td>210 mm</td></tr> <tr><td>Roll Width</td><td>50 mm</td></tr> <tr><td>Roll core</td><td>3 inch = 76 mm</td></tr> <tr><td>Preset length adjustable</td><td>Impossible</td></tr> <tr><td>Adhesive tape type</td><td>Single sided</td></tr> </table>	Weight	340 g	Length/Width/Height	180/85/230 mm	Roll Diameter	210 mm	Roll Width	50 mm	Roll core	3 inch = 76 mm	Preset length adjustable	Impossible	Adhesive tape type	Single sided	 Mountable  Smooth blade
Weight	340 g																
Length/Width/Height	180/85/230 mm																
Roll Diameter	210 mm																
Roll Width	50 mm																
Roll core	3 inch = 76 mm																
Preset length adjustable	Impossible																
Adhesive tape type	Single sided																
<b>tesa®6012</b> <ul style="list-style-type: none"> <li>Special bench dispenser for packaging tapes</li> <li>Can be filled with either one wide roll or two narrow rolls of tape</li> <li>Can be fastened securely with the supplied clamp or with screws on the packing table</li> </ul>		<table border="1"> <tr><td>Weight</td><td>610 g</td></tr> <tr><td>Length/Width/Height</td><td>175/67/130 mm</td></tr> <tr><td>Roll Diameter</td><td>145 mm</td></tr> <tr><td>Roll Width</td><td>1 x 50 mm 2x 25 mm</td></tr> <tr><td>Roll core</td><td>3 inch = 76 mm</td></tr> <tr><td>Preset length adjustable</td><td>Impossible</td></tr> <tr><td>Adhesive tape type</td><td>Single sided</td></tr> </table>	Weight	610 g	Length/Width/Height	175/67/130 mm	Roll Diameter	145 mm	Roll Width	1 x 50 mm 2x 25 mm	Roll core	3 inch = 76 mm	Preset length adjustable	Impossible	Adhesive tape type	Single sided	 Mountable  Smooth blade  Screwable
Weight	610 g																
Length/Width/Height	175/67/130 mm																
Roll Diameter	145 mm																
Roll Width	1 x 50 mm 2x 25 mm																
Roll core	3 inch = 76 mm																
Preset length adjustable	Impossible																
Adhesive tape type	Single sided																
<b>161-6021-N</b> <ul style="list-style-type: none"> <li>Robust table label and die-cut dispenser</li> <li>Can be filled with either one wide roll or two narrow rolls of tape</li> </ul>		<table border="1"> <tr><td>Weight</td><td>1400 g</td></tr> <tr><td>Length/Width/Height</td><td>250/150/130 mm</td></tr> <tr><td>Roll Diameter</td><td>Max. 180 mm</td></tr> <tr><td>Roll Width</td><td>Max. 100 mm</td></tr> <tr><td>Roll core</td><td>Not relevant</td></tr> <tr><td>Preset length adjustable</td><td>Impossible</td></tr> <tr><td>Adhesive tape type</td><td>Label &amp; die-cut</td></tr> </table>	Weight	1400 g	Length/Width/Height	250/150/130 mm	Roll Diameter	Max. 180 mm	Roll Width	Max. 100 mm	Roll core	Not relevant	Preset length adjustable	Impossible	Adhesive tape type	Label & die-cut	 Without blade
Weight	1400 g																
Length/Width/Height	250/150/130 mm																
Roll Diameter	Max. 180 mm																
Roll Width	Max. 100 mm																
Roll core	Not relevant																
Preset length adjustable	Impossible																
Adhesive tape type	Label & die-cut																

## Bag sealing dispenser



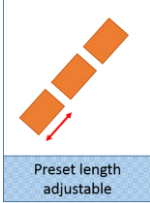
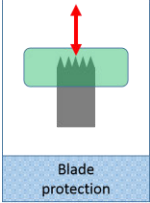

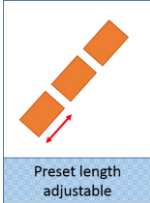
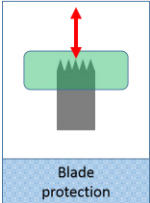

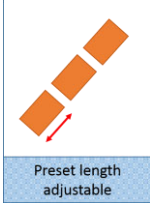
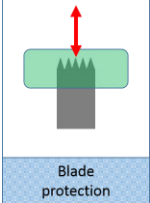

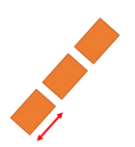

<b>tesa®6094 L</b> <ul style="list-style-type: none"> <li>Bag sealer for medium and large sized bags up to 5 kg weight and diameter of 11mm</li> <li>Hidden blade (blade protection)</li> </ul>		<table border="1"> <tr><td>Weight</td><td>1350 g</td></tr> <tr><td>Length/Width/Height</td><td>210/85/205 mm</td></tr> <tr><td>Roll Diameter</td><td>170 mm</td></tr> <tr><td>Roll Width</td><td>19 mm</td></tr> <tr><td>Roll core</td><td>3 inch = 76 mm</td></tr> <tr><td>Preset length adjustable</td><td>Impossible</td></tr> <tr><td>Adhesive tape type</td><td>Single sided</td></tr> </table>	Weight	1350 g	Length/Width/Height	210/85/205 mm	Roll Diameter	170 mm	Roll Width	19 mm	Roll core	3 inch = 76 mm	Preset length adjustable	Impossible	Adhesive tape type	Single sided	 Screwable  Blade protection
Weight	1350 g																
Length/Width/Height	210/85/205 mm																
Roll Diameter	170 mm																
Roll Width	19 mm																
Roll core	3 inch = 76 mm																
Preset length adjustable	Impossible																
Adhesive tape type	Single sided																
<b>tesa®6256 S</b> <ul style="list-style-type: none"> <li>Like tesa®6094 L, yet for diameter of 6 mm and up to 3 kg weight</li> <li>Hidden blade (blade protection)</li> </ul>		<table border="1"> <tr><td>Weight</td><td>610 g</td></tr> <tr><td>Length/Width/Height</td><td>185/70/270 mm</td></tr> <tr><td>Roll Diameter</td><td>130 mm</td></tr> <tr><td>Roll Width</td><td>12 mm</td></tr> <tr><td>Roll core</td><td>3 inch = 76 mm</td></tr> <tr><td>Preset length adjustable</td><td>Impossible</td></tr> <tr><td>Adhesive tape type</td><td>Single sided</td></tr> </table>	Weight	610 g	Length/Width/Height	185/70/270 mm	Roll Diameter	130 mm	Roll Width	12 mm	Roll core	3 inch = 76 mm	Preset length adjustable	Impossible	Adhesive tape type	Single sided	 Screwable  Blade protection
Weight	610 g																
Length/Width/Height	185/70/270 mm																
Roll Diameter	130 mm																
Roll Width	12 mm																
Roll core	3 inch = 76 mm																
Preset length adjustable	Impossible																
Adhesive tape type	Single sided																





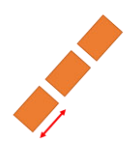







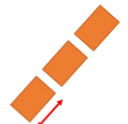

## Semi-automatic dispenser



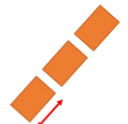



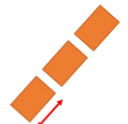





Article	Product picture	Technical data	Features														
<b>161-0237</b> <ul style="list-style-type: none"> <li>① Semi-automatic dispenser for packaging tapes</li> <li>① Tapes is dispensed by pressing the handle</li> <li>① Adjustable pre-set tape length up to 100mm</li> <li>① Hidden blade (blade protection)</li> </ul>		<table border="1"> <tr> <td>Weight</td> <td>1400 g</td> </tr> <tr> <td>Length/Width/Height</td> <td>200/105/125 mm</td> </tr> <tr> <td>Roll Diameter</td> <td>140 mm</td> </tr> <tr> <td>Roll Width</td> <td>25 mm</td> </tr> <tr> <td>Roll core</td> <td>1 or 3 inch</td> </tr> <tr> <td>Preset length adjustable</td> <td>Possible</td> </tr> <tr> <td>Adhesive tape type</td> <td>Single sided</td> </tr> </table>	Weight	1400 g	Length/Width/Height	200/105/125 mm	Roll Diameter	140 mm	Roll Width	25 mm	Roll core	1 or 3 inch	Preset length adjustable	Possible	Adhesive tape type	Single sided	 
Weight	1400 g																
Length/Width/Height	200/105/125 mm																
Roll Diameter	140 mm																
Roll Width	25 mm																
Roll core	1 or 3 inch																
Preset length adjustable	Possible																
Adhesive tape type	Single sided																
<b>tesa®6037</b> <ul style="list-style-type: none"> <li>① Semi-automatic dispenser for packaging tapes</li> <li>① Tapes is dispensed by pressing the handle</li> <li>① Adjustable pre-set tape length up to 100mm</li> <li>① Hidden blade (blade protection)</li> </ul>		<table border="1"> <tr> <td>Weight</td> <td>1400 g</td> </tr> <tr> <td>Length/Width/Height</td> <td>200/105/125 mm</td> </tr> <tr> <td>Roll Diameter</td> <td>140 mm</td> </tr> <tr> <td>Roll Width</td> <td>30 mm</td> </tr> <tr> <td>Roll core</td> <td>3 inch = 76 mm</td> </tr> <tr> <td>Preset length adjustable</td> <td>Possible</td> </tr> <tr> <td>Adhesive tape type</td> <td>Single sided</td> </tr> </table>	Weight	1400 g	Length/Width/Height	200/105/125 mm	Roll Diameter	140 mm	Roll Width	30 mm	Roll core	3 inch = 76 mm	Preset length adjustable	Possible	Adhesive tape type	Single sided	 
Weight	1400 g																
Length/Width/Height	200/105/125 mm																
Roll Diameter	140 mm																
Roll Width	30 mm																
Roll core	3 inch = 76 mm																
Preset length adjustable	Possible																
Adhesive tape type	Single sided																
<b>tesa®6038</b> <ul style="list-style-type: none"> <li>① Semi-automatic dispenser with robust metal case for packaging tapes</li> <li>① Tape is dispensed by pressing the handle</li> <li>① Adjustable pre-set tape length up to 100mm, adjustable by scale</li> <li>① Strips with non-adhesive tab possible (by folding the tape end)</li> <li>① Hidden blade (blade protection)</li> </ul>		<table border="1"> <tr> <td>Weight</td> <td>2600 g</td> </tr> <tr> <td>Length/Width/Height</td> <td>270/120/175 mm</td> </tr> <tr> <td>Roll Diameter</td> <td>140 mm</td> </tr> <tr> <td>Roll Width</td> <td>30 mm</td> </tr> <tr> <td>Roll core</td> <td>3 inch = 76 mm</td> </tr> <tr> <td>Preset length adjustable</td> <td>Possible</td> </tr> <tr> <td>Adhesive tape type</td> <td>Single sided</td> </tr> </table>	Weight	2600 g	Length/Width/Height	270/120/175 mm	Roll Diameter	140 mm	Roll Width	30 mm	Roll core	3 inch = 76 mm	Preset length adjustable	Possible	Adhesive tape type	Single sided	 
Weight	2600 g																
Length/Width/Height	270/120/175 mm																
Roll Diameter	140 mm																
Roll Width	30 mm																
Roll core	3 inch = 76 mm																
Preset length adjustable	Possible																
Adhesive tape type	Single sided																















## Fully automatic dispenser















Article	Product picture	Technical data	Futures															
<b>161-0259</b> <ul style="list-style-type: none"> <li>Fully automatic tape dispenser, especially for Kapton-tapes</li> <li>Preset tape length from 15-70 mm</li> <li>Photocell for automatic donation-spending</li> </ul>		<table border="1"> <tr><td>Weight</td><td>1900 g</td></tr> <tr><td>Length/Width/Height</td><td>258/126/150 mm</td></tr> <tr><td>Roll Diameter</td><td>150 mm</td></tr> <tr><td>Roll Width</td><td>3-25 mm</td></tr> <tr><td>Roll core</td><td>Not relevant</td></tr> <tr><td>Preset length adjustable</td><td>Possible</td></tr> <tr><td>Adhesive tape type</td><td>Single sided</td></tr> </table>	Weight	1900 g	Length/Width/Height	258/126/150 mm	Roll Diameter	150 mm	Roll Width	3-25 mm	Roll core	Not relevant	Preset length adjustable	Possible	Adhesive tape type	Single sided	 Preset length adjustable	 Electrical
Weight	1900 g																	
Length/Width/Height	258/126/150 mm																	
Roll Diameter	150 mm																	
Roll Width	3-25 mm																	
Roll core	Not relevant																	
Preset length adjustable	Possible																	
Adhesive tape type	Single sided																	
<b>161-0256</b> <ul style="list-style-type: none"> <li>Fully automatic tape dispenser</li> <li>Digital Display of the preset length</li> <li>Preset tape length from 20-998 mm</li> <li>Photocell for automatic donation-spending</li> <li>Integrated safety guard mechanism</li> </ul>		<table border="1"> <tr><td>Weight</td><td>2400 g</td></tr> <tr><td>Length/Width/Height</td><td>218/137/150 mm</td></tr> <tr><td>Roll Diameter</td><td>180 mm</td></tr> <tr><td>Roll Width</td><td>7-50 mm</td></tr> <tr><td>Roll core</td><td>3 inch = 76 mm</td></tr> <tr><td>Preset length adjustable</td><td>Possible</td></tr> <tr><td>Adhesive tape type</td><td>Single &amp; Double sided</td></tr> </table>	Weight	2400 g	Length/Width/Height	218/137/150 mm	Roll Diameter	180 mm	Roll Width	7-50 mm	Roll core	3 inch = 76 mm	Preset length adjustable	Possible	Adhesive tape type	Single & Double sided	 Counter	 Preset length adjustable
Weight	2400 g																	
Length/Width/Height	218/137/150 mm																	
Roll Diameter	180 mm																	
Roll Width	7-50 mm																	
Roll core	3 inch = 76 mm																	
Preset length adjustable	Possible																	
Adhesive tape type	Single & Double sided																	
<b>161-0269</b> <ul style="list-style-type: none"> <li>Fully automatic tape dispenser</li> <li>Digital Display</li> <li>6 different preset length can be stored (memory function)</li> <li>Preset tape length from 5-999 mm</li> <li>Photocell for automatic donation-spending</li> <li>No core holder, therefore several different core diameters can be used</li> <li>Automatically stops if tape feed is impaired</li> <li>Different main roller available</li> </ul>		<table border="1"> <tr><td>Weight</td><td>1600 g</td></tr> <tr><td>Length/Width/Height</td><td>213/116/140 mm</td></tr> <tr><td>Roll Diameter</td><td>300 mm</td></tr> <tr><td>Roll Width</td><td>6-60 mm</td></tr> <tr><td>Roll core</td><td>Not relevant</td></tr> <tr><td>Preset length adjustable</td><td>Possible</td></tr> <tr><td>Adhesive tape type</td><td>Single &amp; Double sided</td></tr> </table>	Weight	1600 g	Length/Width/Height	213/116/140 mm	Roll Diameter	300 mm	Roll Width	6-60 mm	Roll core	Not relevant	Preset length adjustable	Possible	Adhesive tape type	Single & Double sided	 Counter	 Preset length adjustable
Weight	1600 g																	
Length/Width/Height	213/116/140 mm																	
Roll Diameter	300 mm																	
Roll Width	6-60 mm																	
Roll core	Not relevant																	
Preset length adjustable	Possible																	
Adhesive tape type	Single & Double sided																	
<b>161-0269-F</b> <ul style="list-style-type: none"> <li>Equivalent to 161-0269</li> <li>Additionally it has an subsidiary function to produce a non-adhesive tab (by folding the tape end)</li> </ul>		<table border="1"> <tr><td>Weight</td><td>1830 g</td></tr> <tr><td>Length/Width/Height</td><td>222/116/148 mm</td></tr> <tr><td>Roll Diameter</td><td>300 mm</td></tr> <tr><td>Roll Width</td><td>6-60 mm</td></tr> <tr><td>Roll core</td><td>Not relevant</td></tr> <tr><td>Preset length adjustable</td><td>Possible</td></tr> <tr><td>Adhesive tape type</td><td>Single &amp; Double sided</td></tr> </table>	Weight	1830 g	Length/Width/Height	222/116/148 mm	Roll Diameter	300 mm	Roll Width	6-60 mm	Roll core	Not relevant	Preset length adjustable	Possible	Adhesive tape type	Single & Double sided	 Counter	 Preset length adjustable
Weight	1830 g																	
Length/Width/Height	222/116/148 mm																	
Roll Diameter	300 mm																	
Roll Width	6-60 mm																	
Roll core	Not relevant																	
Preset length adjustable	Possible																	
Adhesive tape type	Single & Double sided																	

## Fully automatic label & die-cut dispenser

Article	Product picture	Technical data	Futures																		
<b>161-0622-120</b> <ul style="list-style-type: none"> <li>Fully automatic label and die-cut dispenser</li> <li>Photocell for automatic donation-spending</li> <li>The speed of the preset length can be adjusted</li> <li>Incorporated counter</li> <li>Identically constructed dispenser for tapes in:               <ul style="list-style-type: none"> <li>60mm Width: 161-0622-60</li> <li>180mm Width: 161-0622-180</li> </ul> </li> </ul>		<table border="1"> <tr> <td><b>Weight</b></td> <td>2900 g</td> </tr> <tr> <td><b>Length/Width/Height</b></td> <td>200/180/210 mm</td> </tr> <tr> <td><b>Roll Diameter</b></td> <td>210 mm</td> </tr> <tr> <td><b>Roll Width</b></td> <td>20-120 mm</td> </tr> <tr> <td><b>Roll core</b></td> <td>Not relevant</td> </tr> <tr> <td><b>Preset length adjustable</b></td> <td>Possible</td> </tr> <tr> <td><b>Adhesive tape type</b></td> <td>Label &amp; die-cut</td> </tr> </table>	<b>Weight</b>	2900 g	<b>Length/Width/Height</b>	200/180/210 mm	<b>Roll Diameter</b>	210 mm	<b>Roll Width</b>	20-120 mm	<b>Roll core</b>	Not relevant	<b>Preset length adjustable</b>	Possible	<b>Adhesive tape type</b>	Label & die-cut	<table border="1"> <tr> <td style="text-align: center;">             Counter         </td> <td style="text-align: center;">             Preset length adjustable         </td> </tr> <tr> <td style="text-align: center;">             Electrical         </td> <td style="text-align: center;">             Without blade         </td> </tr> </table>	 Counter	 Preset length adjustable	 Electrical	 Without blade
<b>Weight</b>	2900 g																				
<b>Length/Width/Height</b>	200/180/210 mm																				
<b>Roll Diameter</b>	210 mm																				
<b>Roll Width</b>	20-120 mm																				
<b>Roll core</b>	Not relevant																				
<b>Preset length adjustable</b>	Possible																				
<b>Adhesive tape type</b>	Label & die-cut																				
 Counter	 Preset length adjustable																				
 Electrical	 Without blade																				

<b>161-0624-120</b> <ul style="list-style-type: none"> <li>Fully automatic label and die-cut dispenser</li> <li>Photocell for automatic donation-spending</li> <li>The speed of the preset length can be adjusted</li> <li>Incorporated counter</li> <li>Identically constructed dispenser for tapes in:               <ul style="list-style-type: none"> <li>60mm Width: 161-0624-60</li> <li>180mm Width: 161-0624-180</li> </ul> </li> </ul>		<table border="1"> <tr> <td><b>Weight</b></td> <td>3300 g</td> </tr> <tr> <td><b>Length/Width/Height</b></td> <td>231/164/157 mm</td> </tr> <tr> <td><b>Roll Diameter</b></td> <td>250 mm</td> </tr> <tr> <td><b>Roll Width</b></td> <td>20-120 mm</td> </tr> <tr> <td><b>Roll core</b></td> <td>Not relevant</td> </tr> <tr> <td><b>Preset length adjustable</b></td> <td>Possible</td> </tr> <tr> <td><b>Adhesive tape type</b></td> <td>Label &amp; die-cut</td> </tr> </table>	<b>Weight</b>	3300 g	<b>Length/Width/Height</b>	231/164/157 mm	<b>Roll Diameter</b>	250 mm	<b>Roll Width</b>	20-120 mm	<b>Roll core</b>	Not relevant	<b>Preset length adjustable</b>	Possible	<b>Adhesive tape type</b>	Label & die-cut	<table border="1"> <tr> <td style="text-align: center;">             Counter         </td> <td style="text-align: center;">             Preset length adjustable         </td> </tr> <tr> <td style="text-align: center;">             Electrical         </td> <td style="text-align: center;">             Without blade         </td> </tr> </table>	 Counter	 Preset length adjustable	 Electrical	 Without blade
<b>Weight</b>	3300 g																				
<b>Length/Width/Height</b>	231/164/157 mm																				
<b>Roll Diameter</b>	250 mm																				
<b>Roll Width</b>	20-120 mm																				
<b>Roll core</b>	Not relevant																				
<b>Preset length adjustable</b>	Possible																				
<b>Adhesive tape type</b>	Label & die-cut																				
 Counter	 Preset length adjustable																				
 Electrical	 Without blade																				

Product	Type	Weight in g	Length in mm	Width in mm	Height in mm	Max. Roll Diameter in mm	Max. Roll Width in mm	Roll core in inch $\phi$	Preset length adjustable	Adhesive tape type	Page
<b>Hand dispenser</b>											
 161-21401	Profi	410	205	40	210	170	25	3	impossible	Single sided	5
 161-21402	Profi	520	220	65	210	170	50	3	impossible	Single sided	5
 161-21403	Profi	700	215	90	210	170	75	3	impossible	Single sided	5
 505008	Classic	625	180	70	250	136	50	3	impossible	Single sided	6
 505009	Classic	785	180	100	250	136	75	3	impossible	Single sided	6
 161-4200	Classic	500	180	60	230	140	50	3	impossible	Single sided	6
 6300	Classic	350	150	65	240	120	50	3	impossible	Single sided	6
 6400	Classic	500	220	60	220	140	50	3	impossible	Single sided	6
 161-0213	Special	330	150	25	210	150	25	3	impossible	Double-sided	7
 6032	Special	335	220	45	80	150	25	3	impossible	Single sided	7
 6076	Special	500	165	60	130	120	50	3	impossible	Single sided	7
 161-0276-50	Special	480	165	55	125	110	50	3	impossible	Single sided	7
<b>Bench dispenser</b>											
 161-0257	Classic	1280	220	79	90	110	25	1 oder 3	impossible	Single sided	8
 57422	Classic	2000	230	70	130	110	25	3	impossible	Single sided	8
 6090	Classic	2500	270	70	125	125	2 x 25	3	impossible	Single sided	8

Product	Type	Weight in g	Length in mm	Width in mm	Height in mm	Max. Roll Diameter in mm	Max. Roll Width in mm	Roll core in inch ø	Preset length adjustable	Adhesive tape type	Page
<b>Bench dispenser</b>											
 161-6080	Special	3200	260	320	210	140	1 x 100 2 x 50	3	impossible	Single sided	8
 6009	Special	340	180	85	230	210	50	3	impossible	Single sided	9
 6012	Special	610	175	67	130	145	1 x 50 2 x 25	3	impossible	Single sided	9
 161-6021-N	Special	1400	250	150	130	180	100	Not relevant	impossible	Label & die-cut	9
<b>Bag sealing dispenser</b>											
 6094 L	Classic	1200	210	85	205	170	19	3	impossible	Single sided	9
 6256 S	Classic	610	185	70	270	130	12	3	impossible	Single sided	9
<b>Automatic dispenser</b>											
 161-0237	Semi-automatic	1400	200	105	125	140	25	1 oder 3	possible	Single sided	10
 6037	Semi-automatic	1400	200	105	125	140	30	3	possible	Single sided	10
 6038	Semi-automatic	2600	270	120	175	140	30	3	possible	Single sided	10
 161-0259	Fully automatic	1900	258	126	150	150	3-25	Not relevant	possible	Single & double-sided	11
 161-0256	Fully automatic	2400	218	137	150	180	7-60	3	possible	Single & double-sided	11
 161-0269	Fully automatic	1600	213	116	140	300	6-60	Not relevant	possible	Single & double-sided	11
 161-0269-F	Fully automatic	1830	222	116	148	300	6-60	Not relevant	possible	Single & double-sided	11
 161-0622-120	Fully automatic	2900	200	190	180	210	20-120	Not relevant	possible	Label & die-cut	12
 161-0624-120	Fully automatic	3300	231	164	157	250	20-120	Not relevant	possible	Label & die-cut	12

## Accessories

Product picture

description



### Tape holder

- Enables to fix the tape on the tape holder for rolls with max. 320mm external diameter
- Suitable for: 161-0256, 161-0269 and 161-0269-F



### Dispenser holder with tape holder

- Dispenser holder with adjustable slant and tape holder for max. 320mm external diameter
- Suitable for: 161-0256, 161-0269 and 161-0269-F



### Wind gadget

- With the aid of the wind gadget, the release liner will be coiled
- Suitable for: 161-0256, 161-0269 and 161-0269-F



### Dispenser holder with wind gadget

- Special dispenser holder with adjustable slant, and tape holder for max. 150mm external diameter
- With the aid of the wind gadget, the release liner will be coiled
- Suitable for: 161-0256, 161-0269 and 161-0269-F

• Further accessories on enquiry •

For further information please see our other catalogues

In our other catalogues: **Adhesive Tapes for Electrical Insulation**, **double-sided adhesive tapes**, **AcrylicFoamTapes** and **Adhesive Foam tapes** you can receive an overview about the chosen product group and also you will experience further information about construction, application, features and many more.

Get an impression of our other catalogues. Request your catalogue now!

### Adhesive Tapes for Electrical Insulation

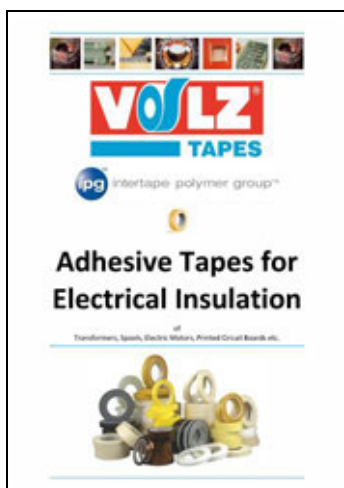

### Double-sided adhesive tapes

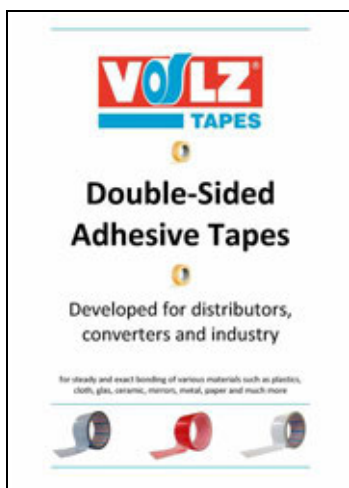

### AcrylicFoamTapes

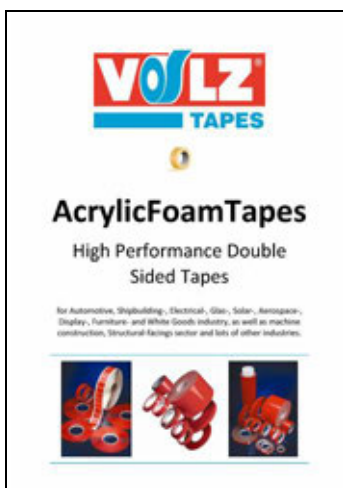

### Adhesive Foam Tapes



