



3M Science.
Applied to Life.™



Best Seller

Your everyday challenges solved. Every day.

3M Industrial Adhesives and Tapes

3M Industrial Adhesives and Tapes

Types of Stress, Surface Energy, Surface Preparation and Application		04
High-Strength Bonding Tapes	3M™ VHB™ Tapes	06
Reclosable Fastening Solutions	3M™ Dual Lock™ Reclosable Fasteners	08
Lightweight Bonding	3M™ Double Coated Tapes	10
Structural Bonding	3M™ Scotch-Weld™ Structural Adhesives	12
Large Surface Bonding	3M™ Spray Adhesives and Cleaners	14
Fast Strength Bonding	3M™ Hot Melt Adhesives	16
Lane Marking & Hazard Warning	3M™ Vinyl Tapes	18
Surface Protection	3M™ Specialty Single Coated Tapes	20
Bundling, reinforcing, palletising, strapping	3M™ Filament High Strength Tapes	22
Maintenance, Repairs & Sealing	3M™ Cloth, Duct and Extreme Sealing Tapes	24
Painting	3M™ Masking Tapes	26
Carton and box sealing	3M™ Box Sealing Tapes	28
Short-length Roll Blister Pack Program	3M™ Best sellers for bonding, fastening and sealing solutions	30

Types of Stress

Preferred Design

With tensile and shear forces, entire bond area contributes to strength

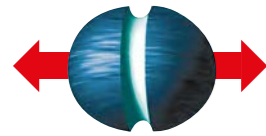

Tensile
Stress acts perpendicular to bond plane

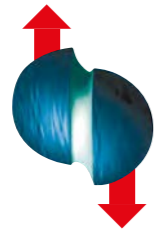

Shear
Stress acts parallel to bond plane

Not Preferred Design

With both cleavage and peel forces, the stresses are concentrated at the leading edge

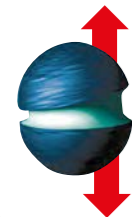

Cleavage
Stress between two rigid substrates

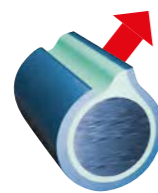

Peel
Stress with at least one flexible substrate

Surface Energy

Choose the right tape for the substrate: Adhesives must flow onto the substrate surfaces in order to achieve intimate contact area

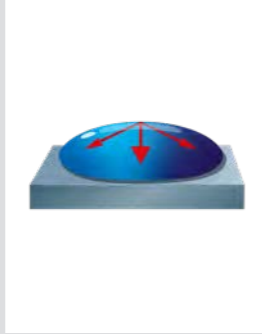

High Surface Energy
Metal, glass



Medium Surface Energy
PET, ABS, PVC (rigid), polycarbonate, polyimide, polyurethane (rigid), acrylic (PMMA), most paints and coatings



Low Surface Energy
Polypropylene, polyethylene, TPO, PTFE, acetyl, PBT, polystyrene, EPDM rubber, some paints and coatings (PVDF)

1. Surface Cleaning

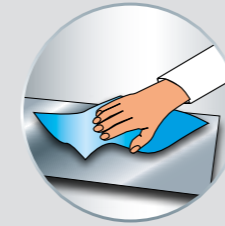

- To obtain optimum adhesion, the bonding surfaces must be well unified, clean and dry
- Wipe surface using an appropriate cleaning agent and a clean cloth
- For glass surfaces use the 3M Silane Glass Primer

2. Application

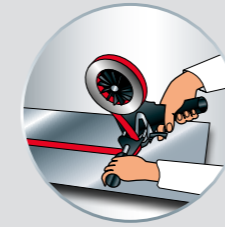

- Apply the tape to the surface. Do not overstretch the tape
- Avoid air pockets
- Do not touch the adhesive or adhesive surface
- Optimum application temperature is between 15°C and 25°C

3. Pressure

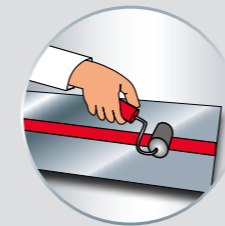

- Bond strength is dependent upon the amount of adhesive-to-surface contact developed
- Firm application pressure develops better adhesive contact and helps improve bond strength

4. Liner Release



- Release the liner in one step (avoid stops)
- Do not touch the adhesive or adhesive surface

5. Joining and Contact Pressure

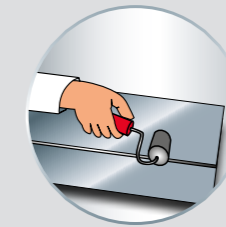

- Apply substrate to the tape
- Avoid air pockets
- Bonding pressure of about 2 kg/cm²

6. Wait for Final Adhesion

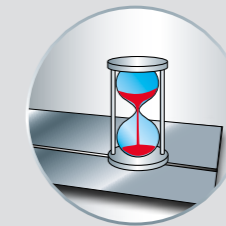

- After application, the bond strength will increase as the adhesive flows onto the surface
- At room temperature, approximately 50% of the ultimate strength will be achieved after 20 minutes, 90% after 24 hours and 100% after 72 hours
- In some cases, bond strength can be increased and ultimate bond strength can be achieved more quickly by exposure of the bond to elevated temperatures (e.g. 66°C for 1 hour)



3M VHB High-Strength Bonding Tapes

With 3M™ VHB™ Tapes, you can maintain consistency from sketch to construction, eliminating distracting, visible fasteners, like screws and bolts. These high-strength, double-sided acrylic foam tapes let you quickly and easily create a long-lasting bond that actually builds strength over time.

A strong, fast and easy way to create durable, reliable bonds.



End User benefits

- Invisible bond: Enhance your design appearance with virtually invisible bonding
- Simplifies and speeds up production processes as it provides immediate handling strength and allows to rout bonded parts faster through manufacturing operations as no curing time is needed
- Allows the use of thinner, lighter weight and dissimilar materials
- A durable difference: With a bond that's built to withstand the rigours of exposure, 3M™ VHB™ Tapes resist hot, cold and cycling temperatures, UV light, moisture, and solvents.
- Demanding strength: For your most demanding bonding applications, 3M™ VHB™ Tapes distribute dynamic or static stress over the entire surface of the design, improving holding strength and eliminating the need for mechanical fasteners
- Energy absorption: Stress and energy is absorbed in the foam and not transferred to the bond line
- Stress relaxation: Over time, stress is relaxed away from the bond, and absorbed by the foam core

Suggested Applications

- Bond panel to frame
- Bond stiffener to panel
- Bond of decorative material, trim, attachments
- Bond of nameplates, logos and signs
- Bond electronic displays
- Bond lens window to housing
- Joining transparent material
- Mount backlit translucent signs
- Assembly of components before heat curing paint processing like powder coating or liquid painting



Best Seller Product Portfolio



3M™ VHB™ Tape 4910
Designed to create durable and reliable bonds of transparent materials or wherever a clear bond is needed.



3M™ VHB™ Tape LSE-110WF
Permanent bond designed for bonding LSE plastics such as PP, TPO, TPE, and composite materials without primer.



3M™ VHB™ Tape 5952
Designed for permanent bonding to powder coated and rigid irregular surfaces. Offers good adhesion to the widest variety of surfaces, including further high and medium surface energy plastics and paints, metals and glass.



3M™ VHB™ Tape GPH-110GF
Designed to create durable and reliable bonds for high temperatures and multi material bonding.



3M™ VHB™ Tape 4941
Designed for permanent bonding with a high bond strength in critical applications on high to medium surface energy materials. Offering plasticiser resistance.

Product Selection Guide

Product number	Properties / suitable for	Surface energy			Material expansion / contraction (dilatation)	Joint gap tolerances	Peel strength (N/cm)	Thickness variations	Key Features	
		High	Medium	Low						
4910	Transparent materials	++	+	-	Max. 1.0 mm	Max. 0.25 mm	26	4905: 0.5 mm 4910: 1.0 mm 4915: 1.5 mm 4918: 2.0 mm	Strong and durable bonds to a wide variety of high to medium surface energy substrates like paints, metals and glass, acryl glass (PMMA), polycarbonate.	
4941	Plasticizer resistant	++	+	-	Max. 3.30 mm	Max. 0.55 mm	35	4936: 0.6 mm 4941: 1.1 mm 4991: 2.3 mm	Strong and durable bonds to a wide variety of high to medium surface energy substrates like aluminium, stainless steel, galvanised steel, polycarbonate, ABS.	
5952	Powder-coated paints	++	++	-	Max. 3.30 mm	Max. 0.55 mm	39	5925: 0.6 mm 5952: 1.1 mm 5962: 1.6 mm	Excellent adhesion to the widest variety of surfaces, including most powder coated paints, metals, glass, sealed wood, acrylic, polycarbonate, ABS.	
GPH-110GF	High temperature resistance	++	+	-	Max. 3.30 mm	Max. 0.55 mm	37	GPH-060GF: 0.6 mm GPH-110GF: 1.1 mm GPH-160GF: 1.6 mm	Excellent temperature resistance when bonding metal parts prior to heat cured paint processing.	
LSE-110WF	PP, TPO, TPE, composite materials	+	++	++	Max. 3.30 mm	Max. 0.55 mm	44	LSE-060WF: 0.6 mm LSE-110WF: 1.1 mm LSE-160WF: 1.6 mm	Offers a superior bonding performance without primer on difficult to bond substrates such as PP, TPO, TPE, and composite materials.	
	3M™ VHB™ Tape Universal Primer UV						Enables strong, durable bonds on surfaces like polypropylene, ABS, PET/PBT blends and other difficult to stick to substrates.			
	VHB™ Surface Cleaner						- Prepares surfaces for bonding - Cleans surfaces to obtain optimum adhesion			



Reclosable Fastening Solutions

3M™ Reclosable Fasteners are the easy alternative to traditional fastening methods such as screws, nuts or bolts. Super strength. Ultimate ease. Durable enough to last through repeated opening and closing.

A strong, durable and versatile hold for ultimate ease.



End User benefits

- Super strength: five times the tensile strength of typical hook-and-loop fasteners
- Clean, smooth “behind the scenes” hold for aesthetic improvements – flexibility to fit your designs
- Maintain surface integrity with no holes to invite moisture, corrosion or dirt
- Simple to apply, use and maintain
- Ability to join dissimilar materials without corrosion and contamination
- Vibration absorption and security, no loosening or failing attachments
- Durable for repeated opening and closings, hundreds of reattachments
- Allows for precise alignment before final closure
- Gives haptic and noise feed back for proper closure
- Reliable performance indoors and outdoors

Suggested Applications

- Panel and cover plate attachment
- Interior signage
- Office partitions
- Graphic attachment
- Access panels
- Specialty vehicles (interior attachments)
- L-bracket edging, repositionable shelving
- Hang signage
- Decorative appliance trim attachment
- Point of purchase display and signage
- Securing fabric to furniture cushions
- Construct composite assemblies
- Attach cushioning panels

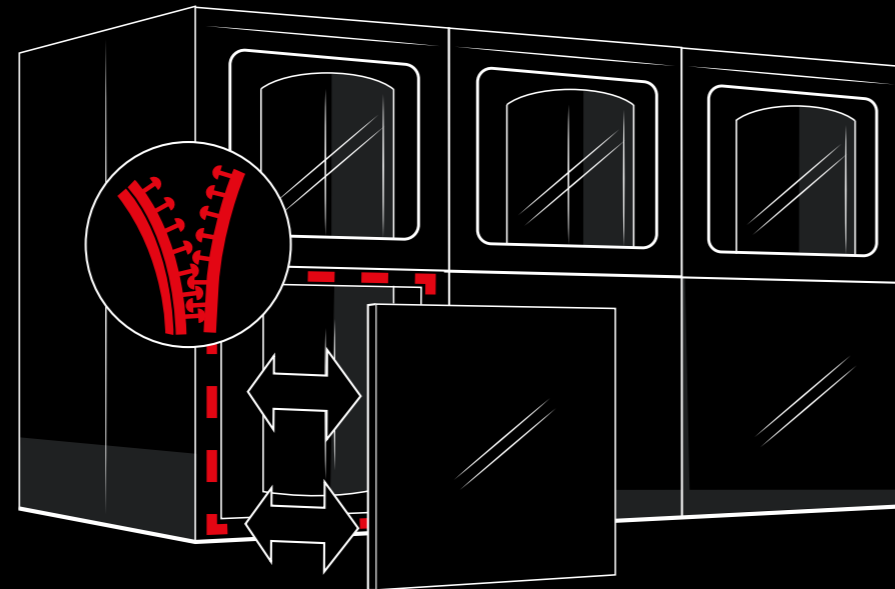

Best Seller Product Portfolio



3M™ Dual Lock™ Reclosable Fastener SJ3540
Designed for use for plastics (acrylic, polycarbonate and ABS), powder-coated paints and low-surface energy materials (polypropylene and polyethylene). Indoor use.



3M™ Dual Lock™ Reclosable Fastener SJ3550
Bonds to a variety of substrates including metals and plastics such as acrylics, polycarbonate and ABS. Indoor and outdoor use.



3M™ Dual Lock™ Reclosable Fastener SJ3560
Designed to give a translucent appearance that bonds to a variety of substrates including metals, glass and plastics such as acrylics, polycarbonate and ABS. Indoor and outdoor use.

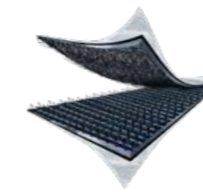

3M™ Hook Fastener SJ3526
3M™ Loop Fastener SJ3527
Alternative to a wide variety of reclosable attachment methods, including zips, screws, snaps, hooks and more.

Product Selection Guide

Product number	Pro- perties / suitable for	Surface energy			Closure cycle life*	Holding power	Engaged thickness	Indoor and outdoor use	Holding power variations	Key Features
		High	Medium	Low						
SJ3526 (Hook) SJ3527 (Loop)	Flexible & bendable	++	++	++	5,000 x		3.6 mm ± 15%		Outdoor use: - SJ3571 (Hook) - SJ3572 (Loop)	Attachment alternative to a wide variety of closures, including zippers, screws, snaps, hooks and more.
SJ3540	Polypropylene & polyethylene	++	++	++	1,000 x		5.7 mm ± 15%		Stem density (per cm²): - SJ3540: 40 - SJ3541: 62 - SJ3542: 26	For use with many plastics (polypropylene, polyethylene, acrylic, polycarbonate and ABS) and powder-coated paints.
SJ3550	Metals & plastics	++	+	-	1,000 x		5.7 mm ± 15%		Stem density (per cm²): - SJ3550: 40 - SJ3551: 62 - SJ3552: 26	Bonds to a variety of substrates including metals and plastics such as acrylics, polycarbonate and ABS.
SJ3560	Translucent materials	++	+	-	1,000 x		5.7 mm ± 15%		Stem density (per cm²): - SJ3560: 40	Designed to give a translucent appearance (glass, acrylic glass (PMMA), polycarbonate).
SJ3870	Powder-coated paints	++	++	-	1,000 x		6.1 mm ± 15%		Stem density (per cm²): - SJ3870: 40	For use with powder-coated paints, metals and plastics such as acrylics, polycarbonate and ABS.
SJ4570	Thin, Low-profile attachment	++	+	-	150 x		2.5 mm ± 15%		Stem density (per cm²): - SJ4570: 109	Low profile attachment for use with powdercoated paints, metals and plastics such as acrylics, polycarbonate and ABS.

*Closings before losing 50% of original tensile strength



Lightweight Bonding

3M™ Double Coated Tapes, developed for good adhesion on high and low surface energy materials providing excellent initial tack supporting your designs. 3M™ Double Coated Tapes are engineered with adhesive on both sides of paper, film or tissue. This increases the dimensional stability of the adhesive for easy handling and application.

The power to bond any job, big or small.



End User benefits

- Invisible bond: Enhance your design appearance with virtually invisible bonding
- Simplifies production processes as it provides an immediate handling strength with no curing time
- Faster: Bond long, large and small surfaces. No prep time. No cure time
- Easier: Apply to a variety of surface shapes and forms, or in awkward positions
- Cost-effective: Refillable applicator distributes what you need with no waste
- Cleaner: Consistent thickness with no mess from oozing, glue lines or overspray
- Convenient: Complete multiple jobs without reloading. Tape is easy to break off and liner is removed automatically. No electricity or hoses needed
- Excellent initial tack for enhanced performance as well as high adhesion to a wide range of surfaces

Suggested Applications

- Bonding and mounting of sales displays and billboards
- Fixing and mounting of decorative trims and emblems
- Use for industrial joining and metal fabrication
- Bonding decorative metal trim
- Bonding flexible printed circuits (FPC) to aluminium stiffener or heat sinks
- Bonding mat board in picture frames and dust covers
- Bonding plastic and wood trim for cabinets
- Splicing of paper, films and foils
- General purpose bindery attachment
- Mounting promotional items and posters
- Bonding thin metal panels

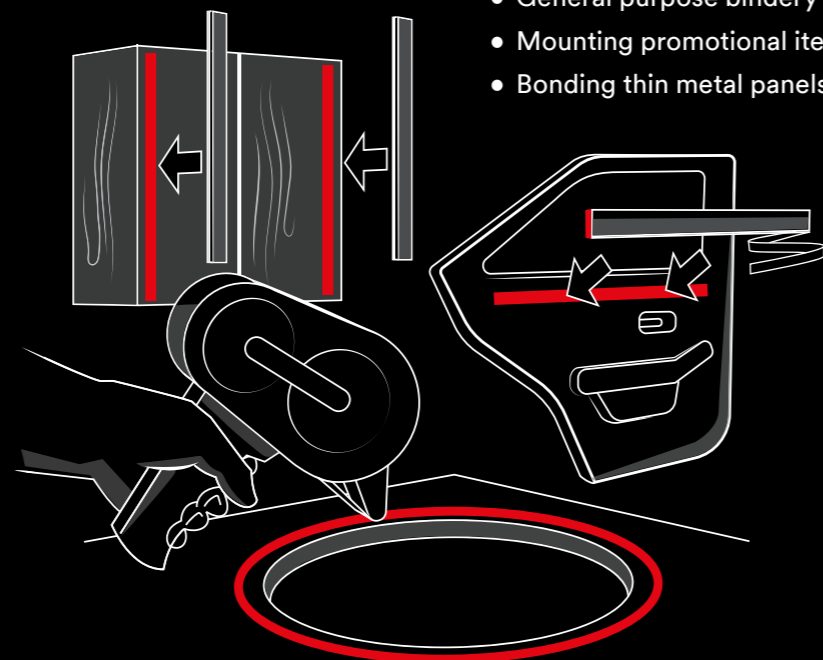

Best Seller Product Portfolio



3M™ Adhesive Transfer Tape 9473PC

High performance tape designed for applications requiring very high shear holding power and bond strength ideally suited to industrial joining and metal fabrication.



Scotch® ATG Adhesive Transfer Tape 924

General-purpose solution for light-duty applications. Offers a clean and permanent bond to a variety of materials such as coated and uncoated paper, lightweight fabrics, foils, flexible plastics and foam boards.



Scotch® ATG Adhesive Transfer Tape 969

Designed for bonding applications requiring very high initial adhesion and good shear holding power for bonding most plastics, glossy coated materials and varied and textured surfaces. Provides good solvent and UV resistance.

Product Selection Guide

Product number ATG System	Product number Transfer Tape	Exceptional holding power	Bond heavy-duty applications	Very high adhesion & good shear holding power	Bond light-duty applications	Excellent resistance to solvents and high temperatures	Bond temporarily	Indoor and outdoor use	Key Features
	9473PC	✓	✓	✓		✓			Very high, shear holding power and bond strength ideally suited to industrial joining and metal fabrication.
	9088-200		✓	✓					Excellent initial tack for enhanced performance as well as high adhesion to a wide range of surfaces.
969	950		✓	✓					Ideal for bonding most plastics and glossy coated materials, fibreglass, foam layers, metal and wood.
924	465				✓				Ideal for use on uncoated and coated paper, card stock, flexible plastics, fabrics and more.
926	9485		✓			✓			Ideal for adhering to metals, ABS, acrylic, PP, PE, polycarbonate, polyester (PET), nylon and other plastics.
928	9415						✓		Designed for reusable, or reclosable applications which allows removal from many papers, foils, and films.

ATG 700 Adhesive Applicator

Touch of the finger triggers quick, controlled application of tape. No mess or clean-up. Saves time and effort. Applies adhesive transfer tape while simultaneously removing and rewinding the liner.



Structural Bonding

3M™ Structural Adhesives. Engineered for strength, design innovation and multi-material assembly. Our Structural Adhesives provide the strength you need while enabling lightweight, high-performance designs and new production realities.

Durable holding power for even the most challenging applications.



End User benefits

- Improve aesthetics: invisible joints, replace rivets, welds and screws, create smoother bond lines
- Lightweighting: eliminate the weight of mechanical fasteners, use thinner, lighter materials
- Freedom to design: bond multiple materials, smaller joints take up less space
- Cost-efficient: use thinner materials to decrease costs, eliminate post-finishing
- Accurate and easy: control dispensing with 3M™ EPX™ exact proportioning and mixing applicators
- Stronger bonds: eliminate stress peaks
- Non-sag formulation ensures adhesive stays where applied
- Resists many chemicals, water, humidity and corrosion
- Provides a strong, permanent bond with high shear strength and good peel even under vibration and impact combined with good flexibility

Suggested Applications

- General attachment applications in a variety of industries
- Joining plastics to metals, such as in the manufacture or repair of appliances
- Impact resistance composite bonding
- Metalworking such as HVAC, appliance, and specialty vehicles
- Sign manufacturing such as panel to frame bonding, trim attachment, letter bonding, and frame assembly
- Bonding plastics, composites and powder coats to metal
- Typically used where fast assembly of smaller parts is required
- Transportation applications, such as rail and automotive
- Semi-flexible potting compound

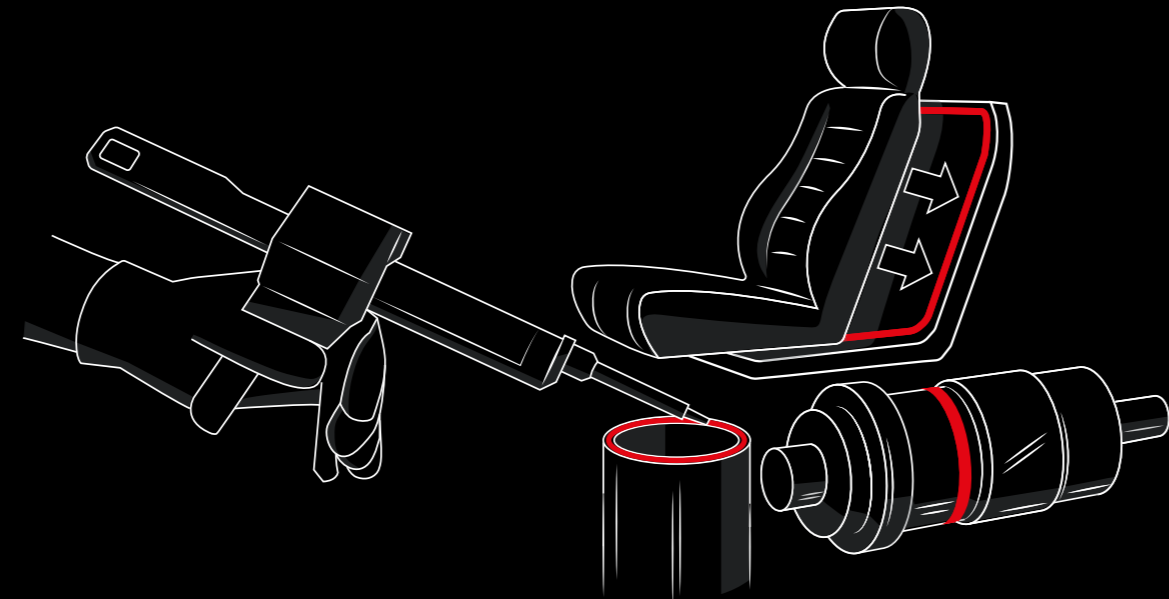

Best Seller Product Portfolio



3M™ Scotch-Weld™ Epoxy Adhesive DP490

Two-part epoxy adhesive with good stability under static and dynamic loads (vibration and impact). Visco-plastic. Longer work life.



3M™ Scotch-Weld™ Structural Plastic Adhesive DP8005

Elastic two-part epoxy adhesive designed for bonding of low surface energy substrates (e.g. polypropylene, polyethylene, TPE – Thermoplastic Elastomers). Very short work life.



3M™ Scotch-Weld™ Epoxy Adhesive DP100 Plus

Very flexible, fast-setting, two-part epoxy adhesive that cures clear and stays clear even when cured in larger masses.



3M™ Scotch-Weld™ Epoxy Adhesive DP190

Two-part epoxy adhesive that features high flexibility and elongation and provides tough, strong bonds through high shear and peel strength. Longer worklife.



3M™ Scotch-Weld™ Epoxy Adhesive 7240 FR

Highly durable two-part epoxy adhesive with high shear and peel adhesion designed to bond metal to metal. Certified for use on trains.

Product Selection Guide

Product number	Static and dynamic loads (vibration and impact)	Bonding of electronic components	Bonding of materials with different dilatation (thermal expansion)	Bonding of polypropylene, polyethylene, TPE	Flame retardant bonding	Surface energy			Approx. work life (min)	Key Features
						High	Medium	Low		
DP410						++	+	-	12	Bonding of medium to high surface energy substrates (e.g. carbon fibre, glass, nylon, powder coated metals).
DP490						++	+	-	90	Outstanding resistance to impact and heat (120 °C) and excellent ageing characteristics.
DP8405						++	++	-	4-6	Bonds to a variety of surfaces, including most metals and many plastics.
DP460						++	+	-	60	Designed for bonding of electronic components.
DP110						++	+	-	8	Versatile bonder for metals, plastics, concrete, wood and composites.
DP190						++	+	-	90	It bonds to a wide range of materials, such as metals, ceramics, wood, fibreboard, glass, rubber and many plastics.
DP100 Plus						++	+	-	4	Very flexible, fast-setting, two-part epoxy adhesive that cures clear and stays clear even when cured in larger masses.
DP8005					✓	++	++	++	2 to 3	Formulated to bond multi-material assemblies such as LSE plastics, thermoplastics, composites and metals.
7240FR						++	-	-	45-60	Highly durable two-part epoxy adhesive with high shear and peel adhesion designed to bond metal to metal. Certified for use on trains.



Large Surface Bonding

At the touch of a finger – bonding power for substrates from paper to metal. 3M's portfolio of industrial-grade spray adhesives is designed to make assembly fast, convenient and efficient.

Bonding power for substrates from paper to metal – at the touch of a finger.



End User benefits

- At the touch of a finger – bonding power for substrates from paper to metal
- Low soak-in property, giving you time to find the best fit for your parts
- Soft, non-dimpling bond lines
- Aggressive tack that offers a high initial grab as well as sufficient open time to position materials properly
- Variable-width lace spray pattern to minimise waste and overspray
- Aggressive tack that offers a high initial grab with foam-tearing strength, yet allows sufficient open time to position materials properly
- Versatile adhesive that bonds a wide range of lightweight materials such as fibreglass, foam, polystyrene, paper, felt, wood, plastic and more
- Fast drying, easy to dispense, transparent high strength spray adhesive that bonds on concrete, wood, MDF, laminates, polyethylene, polypropylene SBR rubber and more

Suggested Applications

- General upholstery and flexible foams bonding (e.g. PU or latex)
- Foam lamination. Attaching foam and fabric to wood and other substrates
- Bond insulating material such as polystyrene, rock wool, glass wool
- Attaching fibreglass insulation and drywall corner beads
- Bond thin decorative film, foils, and fabrics
- For variety of display and furniture jobs
- Picture framing and mounting displays
- Adhere polyethylene, polypropylene to wood, metal and more
- Bond decorative laminate to tables, cabinets and shelving
- Attaching fibreglass insulation and drywall corner beads
- Bond kick plates to office desks
- Attach plastic sign lettering to wood

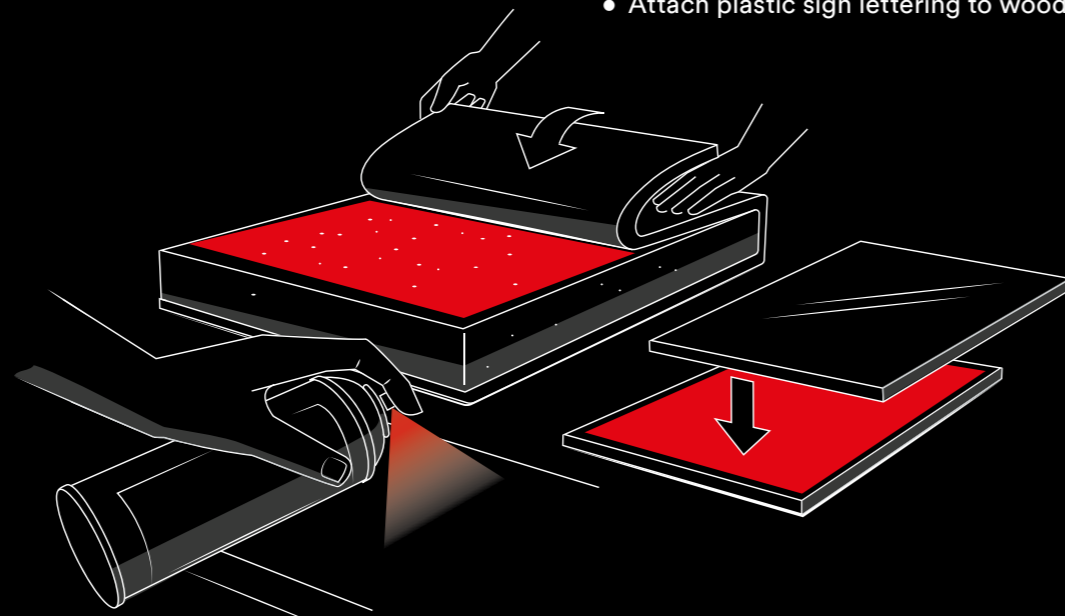

Best Seller Product Portfolio



3M™ Foam Fast 74 Spray Adhesive
Extremely fast tacking adhesive with immediate foam-tearing strength and soft, non-dimpling bond lines that bonds fabrics, foam and upholstery to a variety of substrates and themselves.



3M™ Super 77™ Spray Adhesive
Multipurpose adhesive with a fast, aggressive tack suitable for a wide range of applications, bonding lightweight materials such as fibreglass, foam, paper, felt, wood, plastic and more.



3M™ Hi-Strength 90 Spray Adhesive
A versatile, fast-drying adhesive that forms extremely strong bonds on a wide range of materials such as metals, wood, HPL, rubber, carpet and flooring.



3M™ Industrial Cleaner
The citrus based cleaner can help to prepare surfaces for adhesive bonding and removes dirt, grease, tar and various non-curing adhesives.

Product Selection Guide

Product number	Properties / suitable for	Spray pattern	Key Features
Spray 74	Foam & fabric		- Immediate foam-tearing strength - Soft, non-dimpling bond lines - Bonds fabrics, foam and upholstery to a variety of substrates and themselves
Spray 75	Repositionable & removable		- Suitable for temporarily holding or positioning of lightweight materials
Spray 76	Hi-tack		- High-tack spray adhesive creates strong bonds - Bonds well to many low surface energy materials (polypropylene, polyethylene) and critical paints
Super 77	Multi purpose		- Fast, aggressive tack for a quick bond - Bonds lightweight materials such as fibreglass, foam, polystyrene, paper, felt, wood, plastic and more
Spray 80	Rubber & vinyl		- High strength adhesive provides strong bonds for rubber and vinyl (except EPDM) - Features exceptional heat resistance
Spray 90	Heavy duty & hi-strength		- High heat and moisture resistance - Bonds heavy duty materials such as metals, wood, MDF, laminates, rubber, carpet and flooring and more
Industrial Cleaner	Maintenance & cleaning		- Works without harsh chemicals - Fresh citrus scent - Removes dirt, grease, tar, and many non-curing type adhesives



Fast Strength Bonding

3M™ Hot Melt Adhesives. Superior Bonding. Superior Speed. Improve productivity and aesthetics while lowering costs and minimizing waste with the 3M™ Hot Melt Adhesive System, an environmentally friendly and virtually odourless bonding solution.

Superior bonding. Superior speed.



End User benefits

- Improve your production speed and ease: you can move assemblies immediately and eliminate clamps, fixturing, and drying time and energy
- Improve appearance: hot melt adhesive is virtually invisible between the mating surfaces
- Low melt adhesives are available for lower operating temperatures and bonding heat sensitive surfaces
- Excellent “hot tack”, fast setting for corrugated, beadboard, recoupage, repacking chipboard and wood
- Excellent impact resistance and good shear and peel strength
- Fast, durable product performance for small joint, mounting and trim attachment, large surface lamination and more
- Open bond time allows for fit adjustment and positioning
- Outstanding electrical properties and non-corrosive to copper make it an ideal solution for electrical applications
- High delivery rate and long bonding range

Suggested Applications

- Electronic applications such as potting and wire tacking, and bonding
- Transportation interiors
- Seating attachment
- Manual and corrugated carton sealing
- Repacking chipboard
- Point-of-purchase displays
- Trade exhibits
- Mounting and trim attachment
- Assembly, attaching, repairing, potting, panel bonding, wire tacking, bundling, sealing, encapsulating
- Panel bonding
- Woodworking and furniture manufacturing
- Upholstery

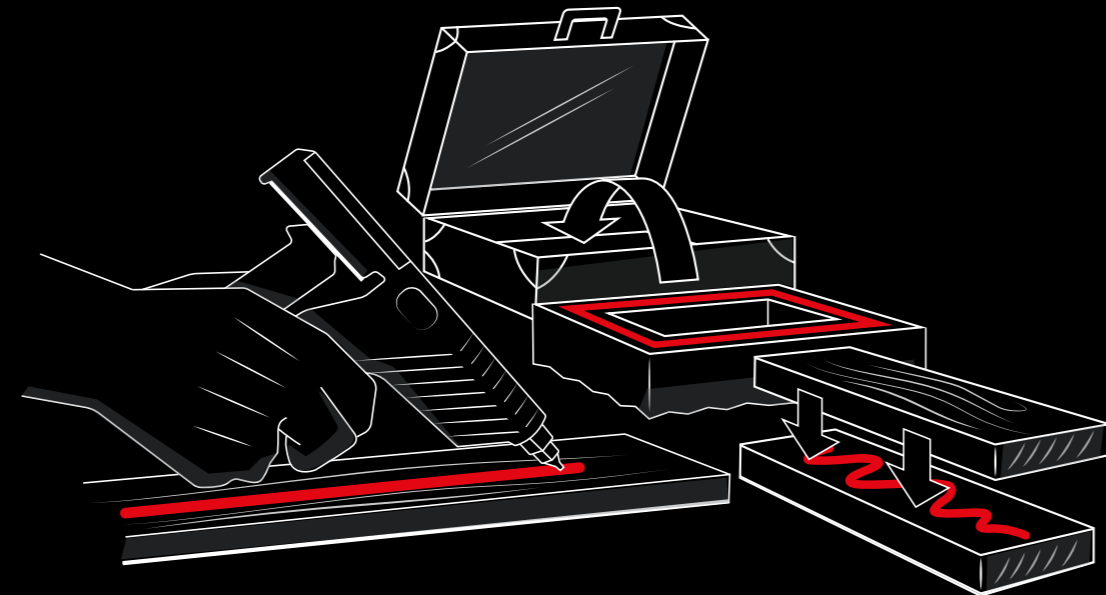

Best Seller Product Portfolio

3M™ Hot Melt Adhesive 3748
Designed for electronic applications: large surface lamination, sealing, potting and encapsulating.

3M™ Hot Melt Adhesive 3762
Designed for packaging and corrugated carton sealing: small joint assembly.

3M™ Hot Melt Adhesive 3764
Designed for bonding plastics, including low surface energy substrates like polycarbonate, polyethylene, and polypropylene.

3M™ Hot Melt Adhesive 3792
Clear, multipurpose hot melt adhesive for wood, fabric, upholstery, and other lightweight materials.

Product Selection Guide

Product number	Wood	Electronics	Cardboard	Plastics	Universal	Key Features
3738						Designed for woodworking and general industrial applications.
3748						Designed for electronic applications: large surface lamination, sealing, potting and encapsulating.
3762						Designed for packaging and corrugated carton sealing: small joint assembly.
3764						Designed for bonding plastics, including low surface energy substrates like polycarbonate, polyethylene, and polypropylene.
3792						Clear, multipurpose hot melt adhesive for wood, fabric, upholstery, and other lightweight materials.



Lane Marking & Hazard Warning

A tape for every job. Whether you're marking a wall, a pipe, or a loading dock, 3M has the right product durability, flexibility and vibrant color you need to help maximize your workflow, safety and factory or warehouse appearance.

Tough jobs call for even tougher tapes.



End User benefits

- Unlike paint solutions, the marking tape is installed quickly and can be removed and cleaned up easily without damaging the respective surface
- Easy to apply, tape stretches around corners for a reliable tight fit
- The adhesive provides a strong bond to most floors and excellent holding power
- Conformable backing makes vinyl tape ideal for use on curved and irregular surfaces
- One-piece clean removal from many surfaces, lower clean up costs
- Colour is integral to tape construction for long-term high visibility and abrasion resistance
- Unique stretch properties enable tape to remain stretched to conform to uneven surfaces without lifting and retracting
- Bright colours for high visibility
- Available in a wide variety of colours and sizes for diverse applications

Suggested Applications

- Lane and safety marking
- Marking of equipment pinch points or gears for warning purposes
- Colour code piping, tools, instruments, etc.
- Protect parts, equipment or products from abrasion
- For taping, wrapping or sealing many curved or convex surfaces
- Floor marking in high traffic areas (pallets and heavy equipment)
- General purpose holding and bundling
- Marking of parts or machines
- Lane and safety marking applications
- Helps identify hazard areas

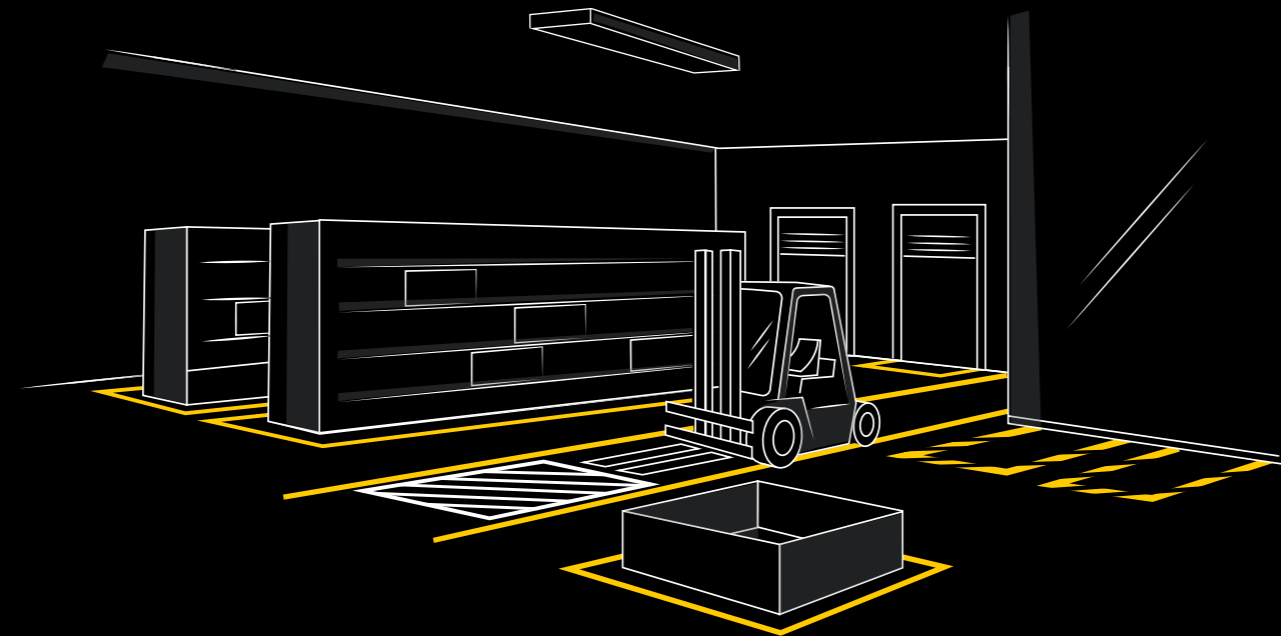

Best Seller Product Portfolio



3M™ Lane and Safety Marking Tape 471

Strength, conformability, instant adhesion and long-term clean removal make 3M™ Vinyl Tape an exceptional choice for floor and safety marking applications.



3M™ General Purpose Vinyl Tape 764

When you're not dealing with tough conditions or the need for a long-term clean removal, this general purpose vinyl tape is a cost-effective choice for a variety of hazard, safety marking, and colour coding applications.



3M™ Ultra Durable Floor Marking Tape 971

Designed for long-term floor marking and engineered for heavy traffic and tough conditions such as scuffing from pallets and heavy equipment.

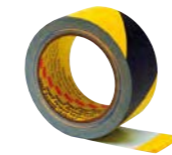

3M™ General Purpose Hazard Warning Tape 766

General purpose striped vinyl tapes in black and yellow ideal for marking of equipment pinch points or gears for warning purposes. It can also be used for floor marking in light traffic areas, and around equipment or spills.

Product Selection Guide

Product number	Colour marking	Floor, wall, or loading dock marking	Hazard area marking	Clean removal	Traffic areas	Key Features
471						Long-term high visibility and abrasion resistance.
971						Scuffing from pallets and heavy equipment, fork-lift traffic.
764						Economical lane and colour marking in noncritical applications.
766						Economical safety marking in noncritical applications.
767						Economical safety marking in noncritical applications.
5702						Long-term high visibility and abrasion resistance.

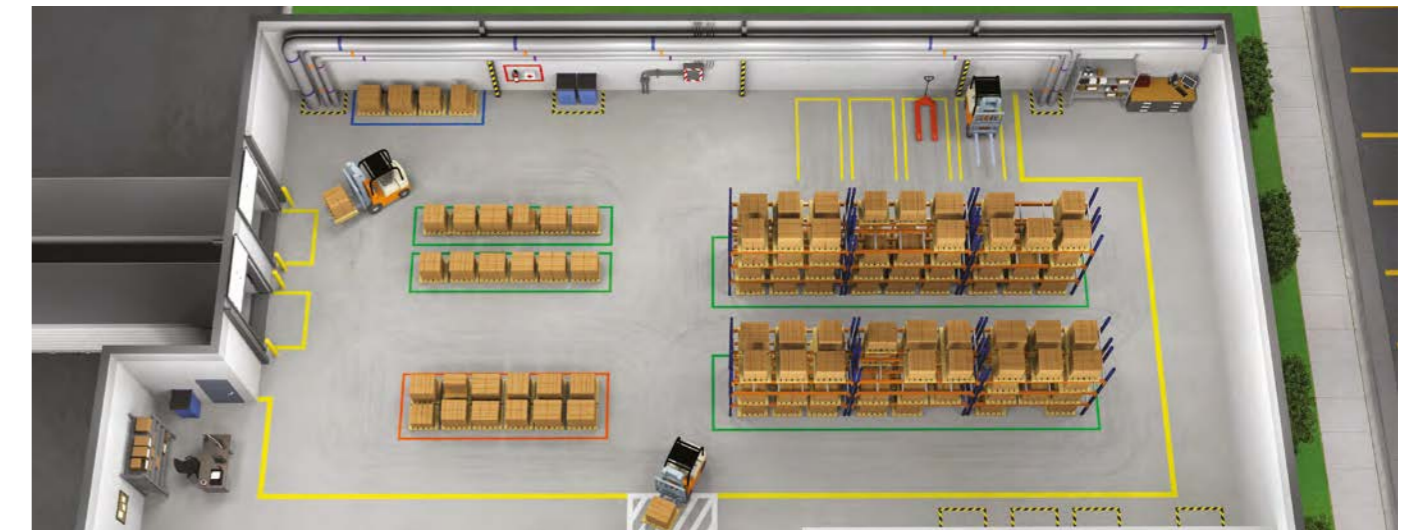

Surface Protection

No matter what your taping situation is, there's a 3M Specialty Tape to help you conduct, reflect, protect, seal, mark, quiet and more. Whatever your application, 3M can meet your needs with a tape to get the job done right.

No matter what your taping situation is, there's a 3M Specialty Tape to help.

End User benefits

- 3M aluminium foil tape 425 can withstand a variety of moisture, weathering, UV and solvents in order to provide an excellent work life, indoors or out
- The light reflective tape enhances lighting efficiency
- High thermal conductivity enhances heating or cooling efficiency
- Due to its exceptional heat resistance and low moisture absorption, 3M glass cloth tape 361 has a wide operating range and also performs in humid environments with intermittent temperatures
- Strong abrasion resistant backing resists shrinking, rotting or burning, providing exceptional stability in harsh environments
- 3M™ UHMW-PE Film Tape 5423 is often used in general industrial applications to help control squeaks and rattles due to vibration or wear of metal and plastic materials
- PTFE tape can be applied to create an easy release surface on machine parts where build-up of sticky materials and inks occur – perfect for the transportation, electronics or metalworking industries
- Slippery, low energy surface for smoother material movement

Suggested Applications

- Heat shielding and heat reflecting of delicate parts
- Masking in chemical paint stripping
- Light reflecting for light enhancement
- Seaming and sealing
- Refrigerator and freezer coil attachment
- Splicing of thin gauge foils
- Permanent sealing of high temperature ducts or chambers
- Use for fabric splicing, seaming and sealing panels
- Reducing squeaks and rattles in automotive and transportation assemblies
- Lining of conveyors, chutes, blades, slides and guide rails
- Separating dissimilar parts to reduce noise and friction
- Protecting aluminium sheets on stretch forming presses
- High temperature wire bundling and harnessing
- Shielding and protecting against chemicals
- Wrapping web rollers to reduce friction

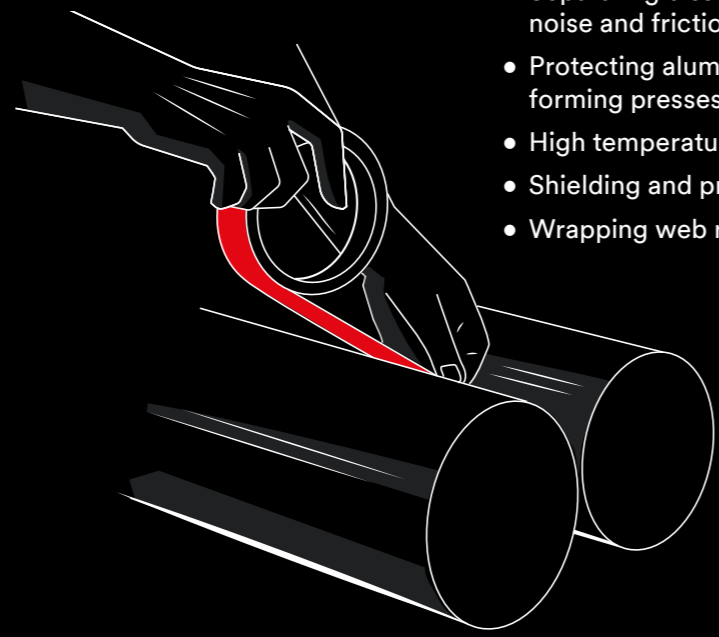

Best Seller Product Portfolio

3M™ Aluminium Foil Tape 425
Designed for heat shielding, heat reflecting, chemical masking, light enhancement, chemical milling, seaming, sealing and de-paint operations. Both indoor and outdoor.

3M™ Glass Cloth Tape 361
For high temperature applications such as sealing ducts and as a back-up strip for submerged arc welding.

3M™ UHMW Film Tape 5423
Designed for applications requiring a low coefficient of friction and the movement of parts and/or materials.

3M™ PTFE Film Tape 5490
Designed to improve surface movement, eliminate squeaks and rattles, and reduce machine noise.

Product Selection Guide

Product number	Lead foil tape	Performance aluminium foil tape	General purpose aluminium foil tape	Noise reduction between dissimilar parts	Protection of grinding areas	Sealing of high-temperature ducts or chambers	Low friction & non-stick surface applications	Key Features
420	✓							Electrically and thermally conductive tape for the electroplating and anodising processes.
431		✓						Designed for heat shielding, heat reflecting, light enhancement, seaming and sealing. Both indoor and outdoor.
425		✓						Designed for heat shielding, heat reflecting, chemical masking, light enhancement, chemical milling, seaming, sealing and de-paint operations. Both indoor and outdoor.
1436			✓					General purpose foil tape ideal for ducting work, sealing and insulation in construction and air conditioning.
5423								Designed for applications requiring a low coefficient of friction and the movement of parts and/or materials.
361								For high temperature applications such as sealing ducts and as a back-up strip for submerged arc welding.
5490								Designed to improve surface movement, eliminate squeaks and rattles, and reduce machine noise.



Bundling, reinforcing, palletising, strapping, heavy box closure

When you need a tape as strong as your reputation, you can count on 3M's consistently reliable, market-leading high strength tapes.

A proven, high strength technology for over 70 years.

End User benefits

- Bonds easily with high initial adhesion to most corrugated fibreboard substrates
- Brands, bar codes and other graphics can be read through the translucent tape
- Able to withstand rough shipping and handling conditions
- Resists nicks, abrasions, moisture, and scuffing
- Adhesive offers excellent balance of initial adhesion and long-term holding power
- Light-duty high strength filament tape for light-duty bundling, reinforcing and pallet unitising applications
- Bi-directionally fibreglass reinforced tape provides cut and tear resistance in machine direction and cross direction
- High tensile strength ideal for heavy duty strapping, bundling, splicing and reinforcing applications

Suggested Applications

- Light-duty strapping, bundling, and reinforcing applications
- Box closing and reinforcing
- Cross web splicing
- Bundling of heavy weight products
- Metal coil tabbing and bundling
- L-clip and U-clip closures
- Pallet unitising, bundling for shipping and handling

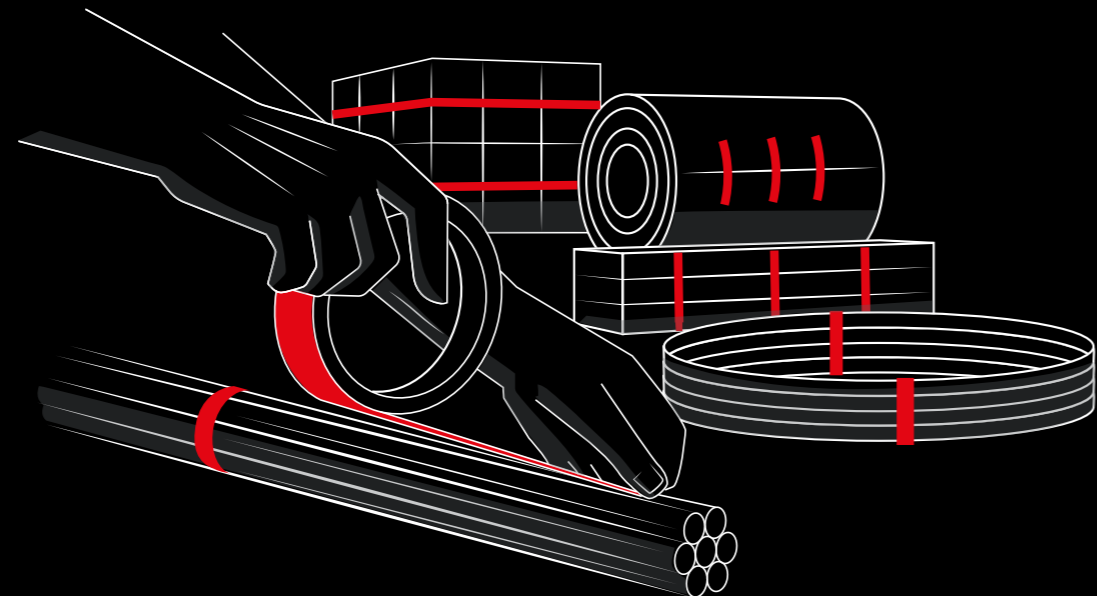

Best Seller Product Portfolio



3M™ Bi-Directional Universal Filament Tape 8959
Universal general purpose high strength filament tape ideal for medium-duty strapping, bundling, splicing, and reinforcing.



3M™ Universal Filament Tape 8956
Universal general purpose filament tape mainly used for holding boxes together on pallets, bundling of lightweight products, closing and reinforcing of fibreboard boxes.



3M™ Filament Tape Performance Plus 8981
Heavy-duty performance filament tape ideal for L-clip and U-clip closures, metal coil tabbing and bundling.

Product Selection Guide

Product number	Properties / suitable for	Light weight bundling & reinforcing	Medium weight bundling & reinforcing	Heavy weight bundling & reinforcing	Clean removal	Key Features
8956	Mono-directional fiberglass reinforced	✓				Light-duty bundling, reinforcing and pallet unitising applications.
8959	Bi-directional fiberglass reinforced		✓			Bi-directionally fibreglass reinforced tape provides cut and tear resistance in machine direction and cross direction.
8981	High Performance			✓		Suitable for L-clip and U-clip closures, metal coil tabbing and bundling.
8915	Removable		✓		✓	Removes cleanly and with a stain resistance to most finishes.
H-180	Box Sealing Tape Dispenser			Portable, lightweight, easy to operate, hand held dispenser with a retractable blade.		





Maintenance, Repairs & Sealing

Built to stick. Whether your surface is smooth and refined, or rough and rugged; whether your job is for one hour or one year, 3M's portfolio of maintenance, repair & sealing tapes meets the industrial demands for sealing, repairing, bundling, coding or fixing in heavy duty or non-critical applications.

Built to stick.
Extremely fast,
clean and easy.

End User benefits

Extreme Sealing Tapes

- Protect and seal with confidence: sticks on contact to many metals and plastics without drying time, dripping, oozing and clean-up
- Conforms over contours, edges, rivets and screw heads for a water tight seal
- Durable sealing that withstands harsh environmental conditions resist UV light, moisture, and solvents for years
- Paintable: you can match most existing colors to blend seamlessly into the surrounding area

Duct & Cloth Tapes

- High instant adhesion – sticks immediately and stays on reliably
- Provides a tight, moisture-resistant seal in many containment situations
- Tears easily by hand, in both directions of the cloth
- Individually wrapped for easy identification and to keep the roll clean until ready for use

Suggested Applications

Extreme Sealing Tapes

- Use for difficult sealing applications like joints, seams or penetration
- Truck and trailer roof sealing
- Skylights sealing
- Window and door sealing
- «Roof-to-trim» sealing

Duct & Cloth Tapes

- Joining and sealing of sheetings, wallboards, metal and plastic ducting
- Splicing of insulation, pipes and panels (hinge effect)
- Cauling and protection with film splicing for treatment or decontamination
- Wrapping of containers and pipes
- Colour coding, marking and labeling
- Container sealing and tarp repair
- Lighter duty applications such as bundling, sealing, holding, labelling and identifying in non-critical applications»

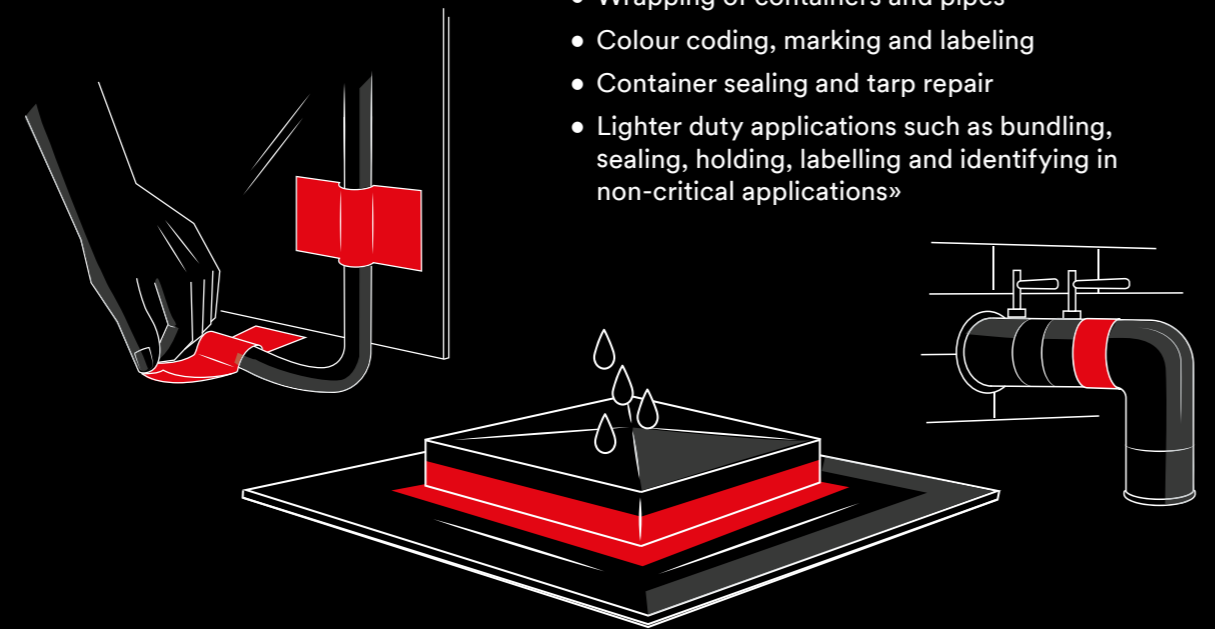

Best Seller Product Portfolio



3M™ Value Duct Tape 1900
Cost-effective duct tape for utility and general use and lighter duty non-critical applications.



3M™ General Purpose Conformable Duct Tape 2903
General purpose conformable duct tape for general maintenance, bundling, wrapping, attaching, sealing, and protecting.



3M™ Extra Heavy Duty Duct Tape 389
Extra heavy duty duct tape tape designed for use in heavy duty industrial and MRO applications.



3M™ Performance Plus Duct Tape 8979
Performance plus duct tape designed for clean removal on most opaque surfaces for up to 6 months in many outdoor and indoor applications.



3M™ Extreme Sealing Tape 4411
Professional seal over an existing joint or seam which can be exposed to direct sunlight, as well as temperature and humidity extremes.

Product Selection Guide

Product number	Properties / suitable for	Indoor and outdoor use	Key Features
1900	Value duct tape		Noncritical light-duty sealing and holding applications
2903	General purpose		General maintenance, bundling, wrapping, attaching, sealing, and protecting
389	Professional grade		- Heavy duty industrial and MRO applications - Colour marking
8979	Clean removal		- Heavy duty industrial and MRO applications - Removes cleanly from most opaque surfaces for up to 6 months
4411	Extreme sealing		- Sealing applications like joints, seams, penetration, roof top, roof-to-trim, skylight - Conforms over contours, edges, rivets and screw heads for a water tight seal



Painting

Masking made simple. Now it's easy to choose the best tape to get industrial jobs done right. This simplified 5-tape system is built on increasing levels of performance and the common goal of helping you finish jobs worth finishing.

Temporary holds you can count on.

End User benefits

- Crepe paper backing for conformability that will maintain integrity when formed around corners
- Good instant adhesion and holding power that resists lifting or curling
- Removes cleanly in one piece with no residue from most surfaces
- Backing saturated for easy tear – resists slivering yet hand tearable
- The tape resists solvents and moisture and will not bleed through – also suitable for use with water-based paint systems
- Helps resist paint bleed through to help create good paint lines
- Excellent UV resistance for long term indoor and outdoor use up to 6 weeks
- It offers a sharp paint line
- Ultra-flat paint edges – extremely thin backing material

Suggested Applications

- Outdoor painting and varnishing work
- Paint masking applications in the building construction market
- Painting in the metal construction market, particularly on delicate surfaces
- Masking for joint sealing applications
- General-purpose industrial paint masking
- Air drying and oven curing of paint and lacquer
- Oven-drying systems, infrared or heat lamps
- Suitable for infrared/UV-curing and bake cycles
- Masking parts for high temperature powder coat painting
- Splicing of silicone liners, films and papers
- Use for temporary fixing, attaching or holding

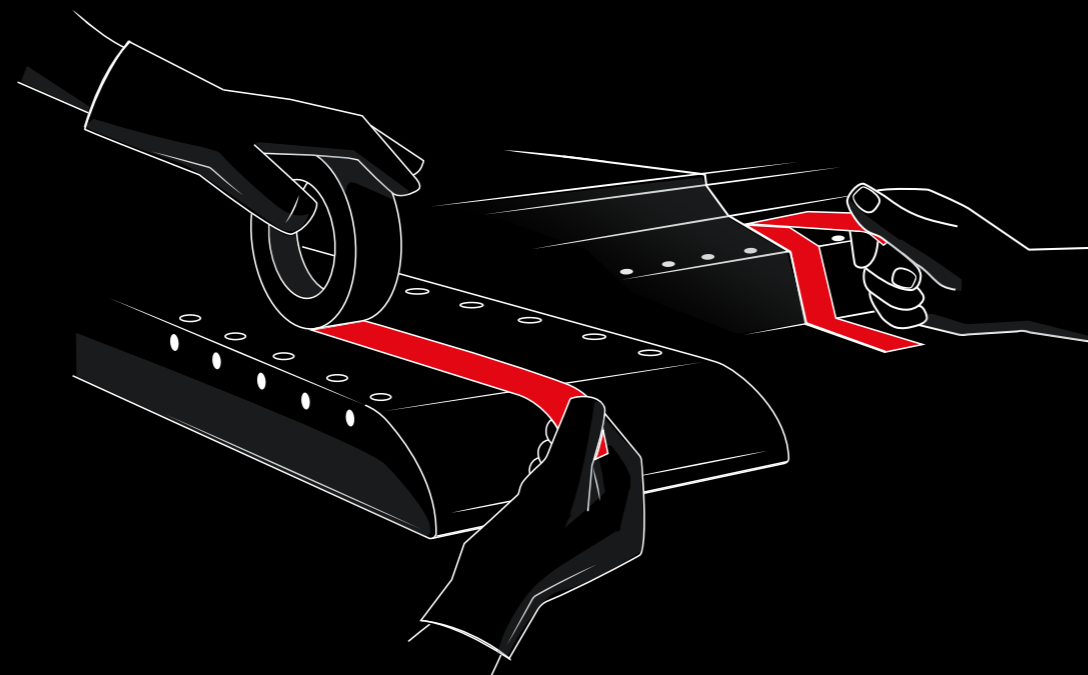

Best Seller Product Portfolio



3M™ Value Masking Tape 101E
Cost-effective general purpose value masking tape for room temperature indoor light-duty applications.



3M™ General Purpose Masking Tape 201E
General purpose masking tape for short-term paint masking and sealing applications.



3M™ Performance Industrial Masking Tape 301E
Performance masking tape for general purpose industrial paint masking applications for air drying and oven curing of paint and lacquer up to a maximum of 100 °C for 1 hour.



3M™ Washi Masking Tape 244
Designed for indoor and outdoor applications where UV resistance, clean removal and sharp paint line is required.

Product Selection Guide

Product number	Period of use (days)	Temperature resistance (°C / 1h)	Indoor and outdoor use	Straight lines and areas masking applications	Sweeping curves masking applications	Powder coating masking applications	Oven-drying systems, IR or heat lamps masking applications	UV-curing & bake cycles masking applications	Automotive masking applications	Key Features
101E	7	60°C	Indoor	✓						Good initial tack to a wide variety of surfaces.
201E	7	80°C	Indoor	✓						Good instant adhesion and holding power that resists lifting or curling.
301E	2	100°C	Indoor	✓						The tape resists solvents and moisture and will not bleed through – also suitable for use with water-based paint systems.
401E	2	140°C	Indoor	✓			✓		✓	Excellent holding power that resists lifting or curling.
501E	2	160°C	Indoor	✓			✓	✓	✓	Holds securely through multiple or extended process cycles.
244	30	100°C	Indoor/Outdoor	✓						Excellent UV resistance for long term indoor and outdoor use up to 6 weeks.
8902	2	204°C	Indoor	✓		✓				Conformable polyester tape ideal for masking in powder coat painting applications and splicing of silicone liners, films and papers.
218	2	120°C	Indoor		✓					Designed to create long straight lines and sweeping curves where a crisp, sharp paint line is desired.





Carton and box sealing

Our carton sealing solutions offer dependable, secure containment and easy application while guaranteeing the best consistency in performance, saving customers time, money and reputations.

Dependable, secure containment and easy application.

End User benefits

- Delivering quality with tapes that keep production lines moving with less interruption and ensure packages are sealed on arrival
- Once applied the product performs well throughout all temperatures typically encountered by packaged products in shipping and storage environments
- Dependable, secure containment and easy application
- Resists splitting when subjected to rough handling and absorbs impact shock
- Adheres instantly to a variety of surfaces and works especially well on challenging recycled corrugate and fibreboard
- Good performance over a broad range of temperatures, specifically in cold and damp applications
- Reduce noise level in the work area with a slow, low noise unwind

Suggested Applications

- Lightweight box sealing
- Medium- to heavy-weight box sealing
- Single strip closure of fibreboard boxes
- Seal boxes with high recycled content
- Heat shrink sealing and bundling lightweight packages

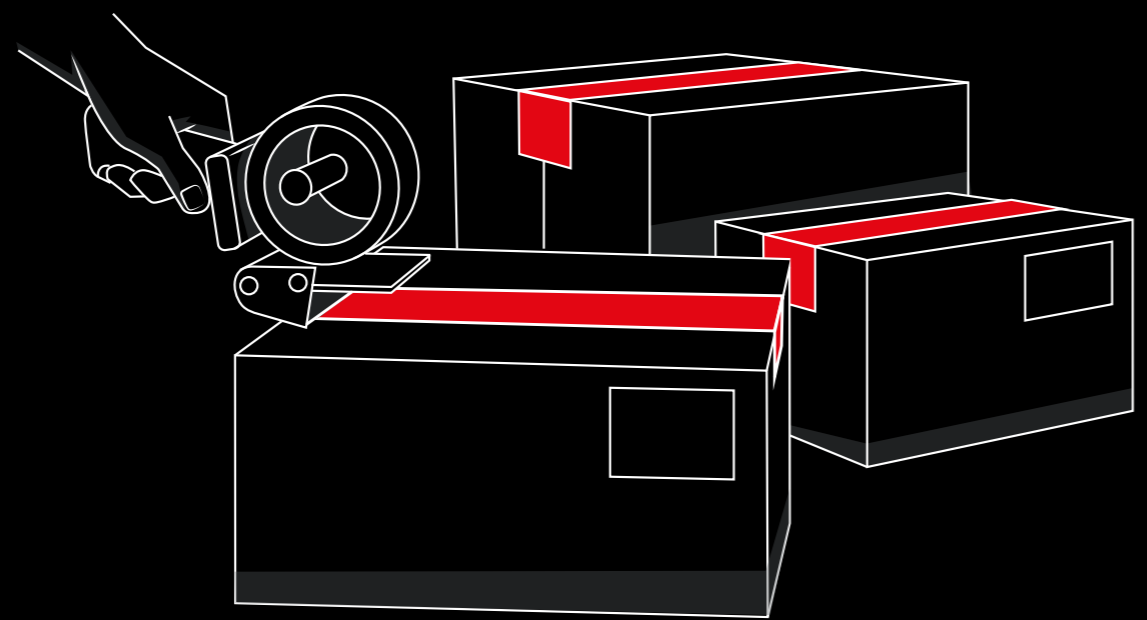

Best Seller Product Portfolio



Scotch® General Purpose Box Sealing Tape 371
 Cost-effective general purpose box sealing tape designed to securely close a wide variety of lightweight box and carton materials, including corrugated fibreboard.

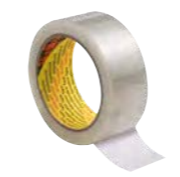

Scotch® General Purpose Low Noise Box Sealing Tape 309
 General purpose low noise box sealing tape suitable for lightweight packaging and price sensitive applications.



Scotch® Performance Box Sealing Tape 3739
 Performance box sealing tape to re-seal and package medium- to heavy-weights of valuable goods.

Product Selection Guide

Product number	Properties / suitable for	Light weight packaging	Medium weight packaging	Medium to heavy weight packaging	Low Noise	Meets FDA requirements	Key Features
371	Economical General purpose						Adheres instantly to a variety of surfaces and works especially well on challenging recycled corrugate and fibreboard.
309	Low noise and Colder & damper						Good performance over a broad range of temperatures, specifically in cold and damp applications.
6890	Recycled Cartons						High initial tack and shear adhesion to fibreboard.
3739	Performance tape						Provides high initial tack and shear adhesion to fibreboard boxes. Suitable for high recycled content corrugated cardboards.
375E	High performance tape						High initial tack and excellent shear adhesion to fibreboard including recycled fibreboards.





3M Short-length Roll Blister Pack Program

Best sellers for bonding, fastening and sealing solutions

You have a job to do. You want the best products to help you do it right.





3M offers the simple solutions to help your work run smoothly:

Whether it's a bonding, fastening or sealing solution you're looking for, with the "short-length roll blister pack everyday essentials program" you can complete everyday jobs quickly and reliably.

- Always convenient – fits in your toolbox
- Always clean – comes in a dirt-protecting blister pack
- Always practical – bonding, fastening and sealing go faster when you've got the right products for the job









3M™ VHB™ High-Strength Bonding Tapes

	Width	Length	Thickness	Colour
 <p>3M™ VHB™ Tape 4910 Designed to create durable and reliable bonds of transparent materials or wherever a clear bond is needed.</p>	19 mm	11 m	1.0 mm	Clear
 <p>3M™ VHB™ Tape 5952 Designed for permanent bonding to powder coated and rigid irregular surfaces. Offers good adhesion to the widest variety of surfaces, including further high and medium surface energy plastics and paints, metals and glass.</p>	19 mm	11 m	1.1 mm	Black
 <p>3M™ VHB™ Tape 5962 Thicker version of 3M™ VHB™ Tape 5952.</p>	19 mm	8 m	1.6 mm	Black
 <p>3M™ VHB™ Tape 4991 Designed for permanent bonding with a high bond strength in critical applications on high to medium surface energy materials. Offering plasticiser resistance.</p>	19 mm	5.5 m	2.3 mm	Grey
<p>3M™ VHB™ Tapes GPH-110GF Designed to create durable and reliable bonds for high temperatures and multi material bonding.</p>	19 mm	11 m	1.1 mm	Grey



3M™ Double Coated Tapes

 <p>3M™ High Performance Double Coated Tape 9088-200 High performance tape that bonds to most substrates, including difficult-to-stick-to substrates. Excellent for applications requiring high adhesion and high transparency.</p>	19 mm	50 m	0.2 mm	Clear
---	-------	------	--------	-------

3M™ Reclosable Fastening Solutions

	Width	Length	Thickness	Colour
 <p>3M™ Dual Lock™ Reclosable Fastener SJ355B Bonds to a variety of substrates including metals and plastics such as acrylics, polycarbonate and ABS. Indoor and outdoor use.</p>	25 mm	2.5 m	5.7 mm	Black
 <p>3M™ Dual Lock™ Reclosable Fastener SJ356B Designed to give a translucent appearance that bonds to a variety of substrates including metals, glass and plastics such as acrylics, polycarbonate and ABS. Indoor and outdoor use.</p>	25 mm	2.5 m	5.7 mm	Translucent
 <p>3M™ Dual Lock™ Reclosable Fastener SJ354B Designed for use for plastics (acrylic, polycarbonate and ABS), powder-coated paints and low-surface energy materials (polypropylene and polyethylene). Indoor use.</p>	25 mm	2.5 m	5.7 mm	Black
 <p>3M™ Dual Lock™ Reclosable Fastener SJ387B Strong, reliable and simple to use reclosable fastener for replacing screws, nails, snaps and rivets. Bonds to a variety of substrates including metals, powder-coated paints and plastics such as acrylics, polycarbonate and ABS. Indoor and outdoor use.</p>	25 mm	2.5 m	6.1 mm	Black
 <p>3M™ 3M™ Hook and Loop Fastener SJ352Bbk (Black) Alternative to a wide variety of reclosable attachment methods, including zips, screws, snaps, hooks and more.</p>	25 mm	1.25 m / each	3.6 mm	Black
 <p>3M™ 3M™ Hook & Loop Fastener SJ352Bwk (White) Alternative to a wide variety of reclosable attachment methods, including zips, screws, snaps, hooks and more.</p>	25 mm	1.25 m / each	3.6 mm	White

3M™ Extreme Sealing Tapes

	Width	Length	Thickness	Colour
 <p>3M™ Extreme Sealing Tape 4411N (Translucent) Professional seal over an existing joint or seam which can be exposed to direct sunlight, as well as temperature and humidity extremes.</p>	50 mm	5.5 m	1.0 mm	Translucent
 <p>3M™ Extreme Sealing Tape 4411B (Black) Professional seal over an existing joint or seam which can be exposed to direct sunlight, as well as temperature and humidity extremes.</p>	50 mm	5.5 m	1.0 mm	Black



Industrial Adhesive and Tapes Advisor

Let us help you find the right product for your needs



Product Use

All statements, technical information, and recommendations contained in this document are based upon tests or experience that 3M believes are reliable and are average values not to be used for specification purposes. However, many factors beyond 3M's control can affect the use and performance of a 3M product in a particular application, including the conditions under which the product is used and the time and environmental conditions in which the product is expected to perform. Since these factors are uniquely within the user's knowledge and control, it is essential that the user evaluates the 3M product to determine whether it is fit for a particular purpose and suitable for the user's method or application. All questions of liability relating to this product are governed by the terms of the sale subject, where applicable, to the prevailing law.



Industrial Adhesives and Tapes Division
3M United Kingdom plc

3M Centre, Cain Road
Bracknell, Berkshire RG12 8HT
Telephone: 0870 60 800 60
www.3M.co.uk/fasteners

3M Ireland Limited

The Iveagh Building
The Park,
Carrickmines Dublin 18
Telephone: 1 800 320 500
www.3Mireland.ie



Presented By:

Volz Selbstklebetechnik GmbH

Fischerinsel 3
DE-79227 Schallstadt
Telephone: +49 (0) 76 64 / 50 500 - 0
Fax: +49 (0) 76 64 / 50 500 - 50
info@volztapes.com / www.volztapes.com