

# Processing Devices

For Single and Double-Sided  
Tapes, Labels and Die-Cuts



VOLZ® TAPES is your specialist in self-adhesive technology. We deliver a large array of technical **self-adhesive tapes, die-cut parts, packing-materials and processing devices.**

In our state-of-the-art production facility, and in close cooperation with you, we develop custom solutions and products to meet your specific application demands. From your first inquiry, to the delivery of the final product from our facility, we develop adhesive tape solutions of the highest quality.

VOLZ® TAPES is not only DIN EN ISO 9001:2015 (Quality Management) and DIN EN ISO 14001:2015 (Environmental Management System) certified, but also a UL certified re-packer, thus fulfilling GS1 standards by participating in the global GS1-System. In our modern equipped laboratory, we conduct all required tests such as: the adhesive peel of 90° & 180°, tensile strength, ultimate elongation, shear strength, rolling ball tack, loop tack and thickness test.

We are an active member of Afera ([www.afera.com](http://www.afera.com)) and conduct our tests by this norm. Upon request, we also conduct tests using other customer required criteria.

Since 2014 we have been developing and producing double-sided adhesive tapes. Whether you need large or small jumbos, log rolls or other cut rolls, spools, plan rolls in neutral or in your own packaging, VOLZ® TAPES has the right solution to meet your most challenging needs.

Tremendous flexibility. Quick response and production times. VOLZ® TAPES is your versatile self-adhesive solutions expert.

### Processing Devices Simplify Your Production Processes

Processing devices rapidly and accurately handle single and double-sided tapes, labels and die-cuts, saving you time and money during production.

On the following pages, you will find an overview of our processing devices including information regarding our hand, bench, automatic tape, label and die-cut dispensers, as well as other accessories to augment your workflow and increase productivity. Matching spare parts and services are available for each individual product.

If the desired product is not listed or if you have any questions, please do not hesitate to contact us. Our contact information may be found on the reverse side of this catalog.

## PACK PROFI Manual Tape Dispenser

### **PACK** PROFI 161-21402 *Manual Tape Dispenser*

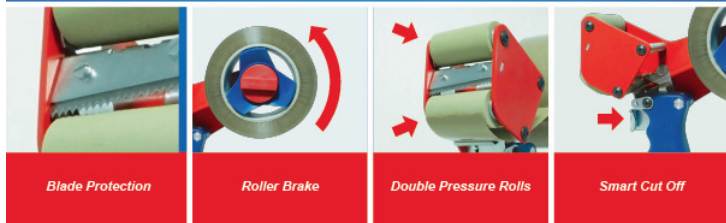
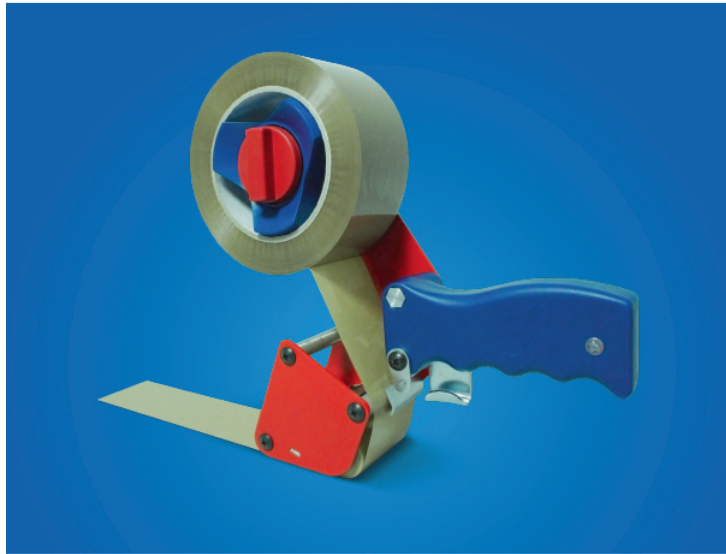

The well tested 161-21402 simply outperforms other professional manual tape dispensers.









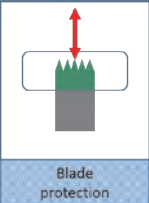

#### Are we proud? Definitely, and for good reasons:

- 1 Ergonomic and easy to handle.
- 1 Roller brake offers easy and fast tape dispensing.
- 1 Double pressure rolls for simple, smooth tape application.
- 1 Strong metal parts, yet still lighter than other top professional manual dispensers.
- 1 Easy trigger release, therefore comfortable for continual, all-day use.
- 1 High-quality, sharp blade with finger protection minimizes stress on device joints and protects the user while providing a clean, straight cut.
- 1 Optimally mounted tension springs minimize the stress on the tape, maintaining tension without overstretching.
- 1 Neutral packaging permits marketing by multiple dealers.

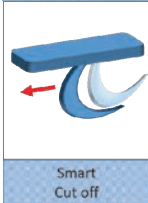

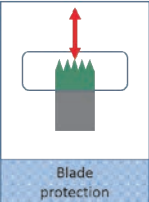

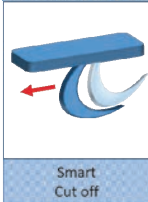

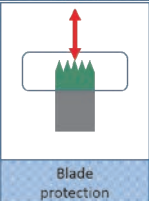
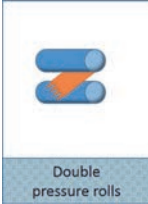
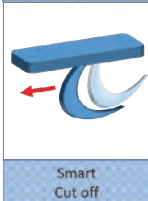

For more information visit our website at [www.tapedispenser.de](http://www.tapedispenser.de) or email us at [info@tapedispenser.de](mailto:info@tapedispenser.de)

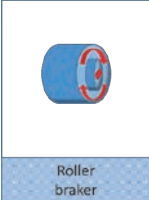

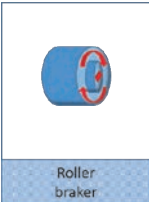
## PACK PROFI Manual Tape Dispensers

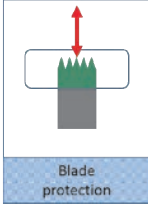
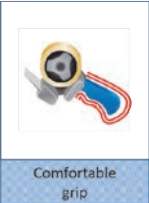

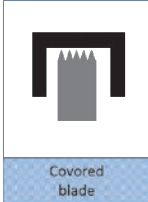

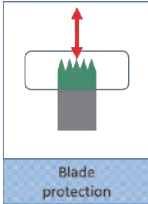
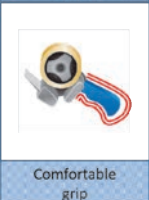

Article	Product picture	Technical data	Features															
<b>161-21401</b> <ul style="list-style-type: none"> <li>🔗 Professional manual tape dispenser for packaging tapes</li> <li>🔗 Tension control adjustable by hand</li> <li>🔗 Two contact pressure rollers allow an especially simple and smooth tape application</li> <li>🔗 Hidden blade (blade protection)</li> <li>🔗 The tape cut-off is implemented by activating the release inside the handle</li> </ul>		<table border="1"> <tr> <td><b>Weight</b></td> <td>410 g</td> </tr> <tr> <td><b>Length/Width/Height</b></td> <td>205/40/210 mm</td> </tr> <tr> <td><b>Roll Diameter</b></td> <td>170 mm</td> </tr> <tr> <td><b>Roll Width</b></td> <td>25 mm</td> </tr> <tr> <td><b>Roll Core</b></td> <td>3 inch = 76 mm</td> </tr> <tr> <td><b>Pre-set Length Adjustable</b></td> <td>No</td> </tr> <tr> <td><b>Adhesive tape type</b></td> <td>Single-Sided</td> </tr> </table>	<b>Weight</b>	410 g	<b>Length/Width/Height</b>	205/40/210 mm	<b>Roll Diameter</b>	170 mm	<b>Roll Width</b>	25 mm	<b>Roll Core</b>	3 inch = 76 mm	<b>Pre-set Length Adjustable</b>	No	<b>Adhesive tape type</b>	Single-Sided	 <p>Roller braker</p>  <p>Blade protection</p>	 <p>Double pressure rolls</p>  <p>Smart Cut off</p>
<b>Weight</b>	410 g																	
<b>Length/Width/Height</b>	205/40/210 mm																	
<b>Roll Diameter</b>	170 mm																	
<b>Roll Width</b>	25 mm																	
<b>Roll Core</b>	3 inch = 76 mm																	
<b>Pre-set Length Adjustable</b>	No																	
<b>Adhesive tape type</b>	Single-Sided																	
<b>161-21402</b> <ul style="list-style-type: none"> <li>🔗 Professional manual tape dispenser for packaging tapes</li> <li>🔗 Tension control adjustable by hand</li> <li>🔗 Two contact pressure rollers allow an especially simple and smooth tape application</li> <li>🔗 Hidden blade (blade protection)</li> <li>🔗 The tape cut-off is implemented by activating the release inside the handle</li> </ul>		<table border="1"> <tr> <td><b>Weight</b></td> <td>520 g</td> </tr> <tr> <td><b>Length/Width/Height</b></td> <td>220/65/210 mm</td> </tr> <tr> <td><b>Roll Diameter</b></td> <td>170 mm</td> </tr> <tr> <td><b>Roll Width</b></td> <td>50 mm</td> </tr> <tr> <td><b>Roll Core</b></td> <td>3 inch = 76 mm</td> </tr> <tr> <td><b>Pre-set Length Adjustable</b></td> <td>No</td> </tr> <tr> <td><b>Adhesive tape type</b></td> <td>Single-Sided</td> </tr> </table>	<b>Weight</b>	520 g	<b>Length/Width/Height</b>	220/65/210 mm	<b>Roll Diameter</b>	170 mm	<b>Roll Width</b>	50 mm	<b>Roll Core</b>	3 inch = 76 mm	<b>Pre-set Length Adjustable</b>	No	<b>Adhesive tape type</b>	Single-Sided	 <p>Roller braker</p>  <p>Blade protection</p>	 <p>Double pressure rolls</p>  <p>Smart Cut off</p>
<b>Weight</b>	520 g																	
<b>Length/Width/Height</b>	220/65/210 mm																	
<b>Roll Diameter</b>	170 mm																	
<b>Roll Width</b>	50 mm																	
<b>Roll Core</b>	3 inch = 76 mm																	
<b>Pre-set Length Adjustable</b>	No																	
<b>Adhesive tape type</b>	Single-Sided																	
<b>161-21403</b> <ul style="list-style-type: none"> <li>🔗 Professional manual tape dispenser for packaging tapes</li> <li>🔗 Tension control adjustable by hand</li> <li>🔗 Two contact pressure rollers allow an especially simple and smooth tape application</li> <li>🔗 Hidden blade (blade protection)</li> <li>🔗 The tape cut-off is implemented by activating the release inside the handle</li> </ul>		<table border="1"> <tr> <td><b>Weight</b></td> <td>700 g</td> </tr> <tr> <td><b>Length/Width/Height</b></td> <td>215/90/210 mm</td> </tr> <tr> <td><b>Roll Diameter</b></td> <td>170 mm</td> </tr> <tr> <td><b>Roll Width</b></td> <td>75 mm</td> </tr> <tr> <td><b>Roll Core</b></td> <td>3 inch = 76 mm</td> </tr> <tr> <td><b>Pre-set Length Adjustable</b></td> <td>No</td> </tr> <tr> <td><b>Adhesive tape type</b></td> <td>Single-Sided</td> </tr> </table>	<b>Weight</b>	700 g	<b>Length/Width/Height</b>	215/90/210 mm	<b>Roll Diameter</b>	170 mm	<b>Roll Width</b>	75 mm	<b>Roll Core</b>	3 inch = 76 mm	<b>Pre-set Length Adjustable</b>	No	<b>Adhesive tape type</b>	Single-Sided	 <p>Roller braker</p>  <p>Blade protection</p>	 <p>Double pressure rolls</p>  <p>Smart Cut off</p>
<b>Weight</b>	700 g																	
<b>Length/Width/Height</b>	215/90/210 mm																	
<b>Roll Diameter</b>	170 mm																	
<b>Roll Width</b>	75 mm																	
<b>Roll Core</b>	3 inch = 76 mm																	
<b>Pre-set Length Adjustable</b>	No																	
<b>Adhesive tape type</b>	Single-Sided																	

## Classic Hand Dispensers

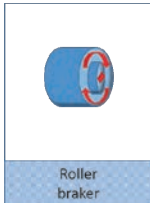

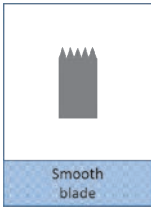

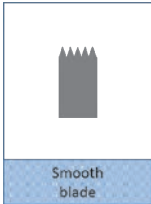
Article	Product picture	Technical data	Features														
<b>505008</b> <ul style="list-style-type: none"> <li>Hand dispenser for packaging tapes</li> <li>Tension control adjustable by hand</li> </ul>		<table border="1"> <tr><td>Weight</td><td>625 g</td></tr> <tr><td>Length/Width/Height</td><td>180/70/250 mm</td></tr> <tr><td>Roll Diameter</td><td>136 mm</td></tr> <tr><td>Roll Width</td><td>50 mm</td></tr> <tr><td>Roll Core</td><td>3 inch = 76 mm</td></tr> <tr><td>Pre-set Length Adjustable</td><td>No</td></tr> <tr><td>Adhesive tape type</td><td>Single-Sided</td></tr> </table>	Weight	625 g	Length/Width/Height	180/70/250 mm	Roll Diameter	136 mm	Roll Width	50 mm	Roll Core	3 inch = 76 mm	Pre-set Length Adjustable	No	Adhesive tape type	Single-Sided	
Weight	625 g																
Length/Width/Height	180/70/250 mm																
Roll Diameter	136 mm																
Roll Width	50 mm																
Roll Core	3 inch = 76 mm																
Pre-set Length Adjustable	No																
Adhesive tape type	Single-Sided																
<b>505009</b> <ul style="list-style-type: none"> <li>Hand dispenser for packaging tapes</li> <li>Tension control adjustable by hand</li> </ul>		<table border="1"> <tr><td>Weight</td><td>785 g</td></tr> <tr><td>Length/Width/Height</td><td>180/100/250 mm</td></tr> <tr><td>Roll Diameter</td><td>136 mm</td></tr> <tr><td>Roll Width</td><td>75 mm</td></tr> <tr><td>Roll Core</td><td>3 inch = 76 mm</td></tr> <tr><td>Pre-set Length Adjustable</td><td>No</td></tr> <tr><td>Adhesive tape type</td><td>Single-Sided</td></tr> </table>	Weight	785 g	Length/Width/Height	180/100/250 mm	Roll Diameter	136 mm	Roll Width	75 mm	Roll Core	3 inch = 76 mm	Pre-set Length Adjustable	No	Adhesive tape type	Single-Sided	
Weight	785 g																
Length/Width/Height	180/100/250 mm																
Roll Diameter	136 mm																
Roll Width	75 mm																
Roll Core	3 inch = 76 mm																
Pre-set Length Adjustable	No																
Adhesive tape type	Single-Sided																
<b>161-4200</b> <ul style="list-style-type: none"> <li>Hand dispenser for packaging tapes</li> <li>Tension control adjustable by hand</li> <li>Hidden blade (blade protection)</li> <li>Soft gummed handle for a comfortable, secure grip</li> </ul>		<table border="1"> <tr><td>Weight</td><td>500 g</td></tr> <tr><td>Length/Width/Height</td><td>180/60/230 mm</td></tr> <tr><td>Roll Diameter</td><td>140 mm</td></tr> <tr><td>Roll Width</td><td>50 mm</td></tr> <tr><td>Roll Core</td><td>3 inch = 76 mm</td></tr> <tr><td>Pre-set Length Adjustable</td><td>No</td></tr> <tr><td>Adhesive tape type</td><td>Single-Sided</td></tr> </table>	Weight	500 g	Length/Width/Height	180/60/230 mm	Roll Diameter	140 mm	Roll Width	50 mm	Roll Core	3 inch = 76 mm	Pre-set Length Adjustable	No	Adhesive tape type	Single-Sided	  
Weight	500 g																
Length/Width/Height	180/60/230 mm																
Roll Diameter	140 mm																
Roll Width	50 mm																
Roll Core	3 inch = 76 mm																
Pre-set Length Adjustable	No																
Adhesive tape type	Single-Sided																
<b>tesa® 6300</b> <ul style="list-style-type: none"> <li>tesa® hand dispenser for packaging tapes</li> <li>Tension control adjustable by hand</li> <li>Covered blade</li> </ul>		<table border="1"> <tr><td>Weight</td><td>350 g</td></tr> <tr><td>Length/Width/Height</td><td>150/65/240 mm</td></tr> <tr><td>Roll Diameter</td><td>120 mm</td></tr> <tr><td>Roll Width</td><td>50 mm</td></tr> <tr><td>Roll Core</td><td>3 inch = 76 mm</td></tr> <tr><td>Pre-set Length Adjustable</td><td>No</td></tr> <tr><td>Adhesive tape type</td><td>Single-Sided</td></tr> </table>	Weight	350 g	Length/Width/Height	150/65/240 mm	Roll Diameter	120 mm	Roll Width	50 mm	Roll Core	3 inch = 76 mm	Pre-set Length Adjustable	No	Adhesive tape type	Single-Sided	 
Weight	350 g																
Length/Width/Height	150/65/240 mm																
Roll Diameter	120 mm																
Roll Width	50 mm																
Roll Core	3 inch = 76 mm																
Pre-set Length Adjustable	No																
Adhesive tape type	Single-Sided																
<b>tesa® 6400</b> <ul style="list-style-type: none"> <li>Professional tesa® hand dispenser for packaging tapes</li> <li>Tension control adjustable by hand</li> <li>Hidden blade (injury protection)</li> <li>Soft gummed handle for a comfortable, secure grip</li> </ul>		<table border="1"> <tr><td>Weight</td><td>500 g</td></tr> <tr><td>Length/Width/Height</td><td>220/60/220 mm</td></tr> <tr><td>Roll Diameter</td><td>140 mm</td></tr> <tr><td>Roll Width</td><td>50 mm</td></tr> <tr><td>Roll Core</td><td>3 inch = 76 mm</td></tr> <tr><td>Pre-set Length Adjustable</td><td>No</td></tr> <tr><td>Adhesive tape type</td><td>Single-Sided</td></tr> </table>	Weight	500 g	Length/Width/Height	220/60/220 mm	Roll Diameter	140 mm	Roll Width	50 mm	Roll Core	3 inch = 76 mm	Pre-set Length Adjustable	No	Adhesive tape type	Single-Sided	  
Weight	500 g																
Length/Width/Height	220/60/220 mm																
Roll Diameter	140 mm																
Roll Width	50 mm																
Roll Core	3 inch = 76 mm																
Pre-set Length Adjustable	No																
Adhesive tape type	Single-Sided																

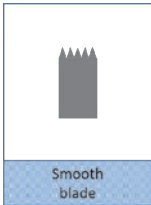

## Special Hand Dispensers

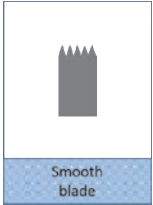
Article	Product picture	Technical data	Features														
<b>161-0213</b> <ul style="list-style-type: none"> <li>Hand dispenser for Double-sided tapes</li> <li>Release paper rewind</li> <li>Adjustable brake, stop trigger cuts the tape</li> </ul>		<table border="1"> <tr><td>Weight</td><td>330 g</td></tr> <tr><td>Length/Width/Height</td><td>150/25/210 mm</td></tr> <tr><td>Roll Diameter</td><td>150 mm</td></tr> <tr><td>Roll Width</td><td>25 mm</td></tr> <tr><td>Roll Core</td><td>3 inch = 76 mm</td></tr> <tr><td>Pre-set Length Adjustable</td><td>No</td></tr> <tr><td>Adhesive tape type</td><td>Double-Sided</td></tr> </table>	Weight	330 g	Length/Width/Height	150/25/210 mm	Roll Diameter	150 mm	Roll Width	25 mm	Roll Core	3 inch = 76 mm	Pre-set Length Adjustable	No	Adhesive tape type	Double-Sided	 
Weight	330 g																
Length/Width/Height	150/25/210 mm																
Roll Diameter	150 mm																
Roll Width	25 mm																
Roll Core	3 inch = 76 mm																
Pre-set Length Adjustable	No																
Adhesive tape type	Double-Sided																
<b>tesa® 6032</b> <ul style="list-style-type: none"> <li>Special hand dispenser for filament and strapping tapes</li> <li>Special blade to cut filament reinforced packaging tapes</li> </ul>		<table border="1"> <tr><td>Weight</td><td>335 g</td></tr> <tr><td>Length/Width/Height</td><td>220/45/80 mm</td></tr> <tr><td>Roll Diameter</td><td>150 mm</td></tr> <tr><td>Roll Width</td><td>25 mm</td></tr> <tr><td>Roll Core</td><td>3 inch = 76 mm</td></tr> <tr><td>Pre-set Length Adjustable</td><td>No</td></tr> <tr><td>Adhesive tape type</td><td>Single-Sided</td></tr> </table>	Weight	335 g	Length/Width/Height	220/45/80 mm	Roll Diameter	150 mm	Roll Width	25 mm	Roll Core	3 inch = 76 mm	Pre-set Length Adjustable	No	Adhesive tape type	Single-Sided	
Weight	335 g																
Length/Width/Height	220/45/80 mm																
Roll Diameter	150 mm																
Roll Width	25 mm																
Roll Core	3 inch = 76 mm																
Pre-set Length Adjustable	No																
Adhesive tape type	Single-Sided																
<b>tesa® 6076</b> <ul style="list-style-type: none"> <li>Special hand dispenser with robust metal housing for packaging tapes</li> </ul>		<table border="1"> <tr><td>Weight</td><td>500 g</td></tr> <tr><td>Length/Width/Height</td><td>165/60/130 mm</td></tr> <tr><td>Roll Diameter</td><td>120 mm</td></tr> <tr><td>Roll Width</td><td>50 mm</td></tr> <tr><td>Roll Core</td><td>3 inch = 76 mm</td></tr> <tr><td>Pre-set Length Adjustable</td><td>No</td></tr> <tr><td>Adhesive tape type</td><td>Single-Sided</td></tr> </table>	Weight	500 g	Length/Width/Height	165/60/130 mm	Roll Diameter	120 mm	Roll Width	50 mm	Roll Core	3 inch = 76 mm	Pre-set Length Adjustable	No	Adhesive tape type	Single-Sided	
Weight	500 g																
Length/Width/Height	165/60/130 mm																
Roll Diameter	120 mm																
Roll Width	50 mm																
Roll Core	3 inch = 76 mm																
Pre-set Length Adjustable	No																
Adhesive tape type	Single-Sided																
<b>161-0270-50</b> <ul style="list-style-type: none"> <li>Special hand dispenser with robust metal housing for packaging tapes</li> <li>Identically constructed dispenser for tapes in:  19mm Width: 161-0270-19  25mm Width: 161-0270-25  30mm Width: 161-0270-30  38mm Width: 161-0270-38</li> </ul>		<table border="1"> <tr><td>Weight</td><td>480 g</td></tr> <tr><td>Length/Width/Height</td><td>165/55/125 mm</td></tr> <tr><td>Roll Diameter</td><td>110 mm</td></tr> <tr><td>Roll Width</td><td>50 mm</td></tr> <tr><td>Roll Core</td><td>3 inch = 76 mm</td></tr> <tr><td>Pre-set Length Adjustable</td><td>No</td></tr> <tr><td>Adhesive tape type</td><td>Single-Sided</td></tr> </table>	Weight	480 g	Length/Width/Height	165/55/125 mm	Roll Diameter	110 mm	Roll Width	50 mm	Roll Core	3 inch = 76 mm	Pre-set Length Adjustable	No	Adhesive tape type	Single-Sided	
Weight	480 g																
Length/Width/Height	165/55/125 mm																
Roll Diameter	110 mm																
Roll Width	50 mm																
Roll Core	3 inch = 76 mm																
Pre-set Length Adjustable	No																
Adhesive tape type	Single-Sided																

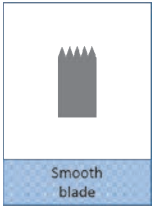
## Classic Bench Dispensers

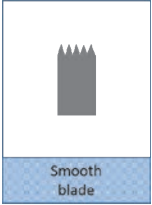
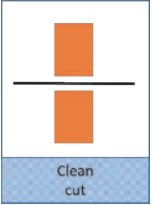
Article	Product picture	Technical data	Features														
<b>161-0257</b> <ul style="list-style-type: none"> <li>Bench dispenser for processing tapes</li> <li>For 1"-core or also 3"-core</li> <li>Non-slip</li> </ul>		<table border="1"> <tr><td>Weight</td><td>1280 g</td></tr> <tr><td>Length/Width/Height</td><td>220/79/90 mm</td></tr> <tr><td>Roll Diameter</td><td>110 mm</td></tr> <tr><td>Roll Width</td><td>25 mm</td></tr> <tr><td>Roll Core</td><td>1 or 3 inch</td></tr> <tr><td>Pre-set Length Adjustable</td><td>No</td></tr> <tr><td>Adhesive tape type</td><td>Single-Sided</td></tr> </table>	Weight	1280 g	Length/Width/Height	220/79/90 mm	Roll Diameter	110 mm	Roll Width	25 mm	Roll Core	1 or 3 inch	Pre-set Length Adjustable	No	Adhesive tape type	Single-Sided	
Weight	1280 g																
Length/Width/Height	220/79/90 mm																
Roll Diameter	110 mm																
Roll Width	25 mm																
Roll Core	1 or 3 inch																
Pre-set Length Adjustable	No																
Adhesive tape type	Single-Sided																
<b>tesa®57422</b> <ul style="list-style-type: none"> <li>Bench dispenser for processing tapes</li> <li>Non-slip base, sturdy case</li> <li>Serrated blade for a clean, convenient cut</li> </ul>		<table border="1"> <tr><td>Weight</td><td>2000 g</td></tr> <tr><td>Length/Width/Height</td><td>230/70/130 mm</td></tr> <tr><td>Roll Diameter</td><td>110 mm</td></tr> <tr><td>Roll Width</td><td>25 mm</td></tr> <tr><td>Roll Core</td><td>3 inch = 76 mm</td></tr> <tr><td>Pre-set Length Adjustable</td><td>No</td></tr> <tr><td>Adhesive tape type</td><td>Single-Sided</td></tr> </table>	Weight	2000 g	Length/Width/Height	230/70/130 mm	Roll Diameter	110 mm	Roll Width	25 mm	Roll Core	3 inch = 76 mm	Pre-set Length Adjustable	No	Adhesive tape type	Single-Sided	
Weight	2000 g																
Length/Width/Height	230/70/130 mm																
Roll Diameter	110 mm																
Roll Width	25 mm																
Roll Core	3 inch = 76 mm																
Pre-set Length Adjustable	No																
Adhesive tape type	Single-Sided																
<b>tesa®6090</b> <ul style="list-style-type: none"> <li>Robust bench dispenser with steel case for strapping and packaging tapes</li> <li>For up to two rolls</li> <li>Separate blade for each roll</li> </ul>		<table border="1"> <tr><td>Weight</td><td>2500 g</td></tr> <tr><td>Length/Width/Height</td><td>270/70/125 mm</td></tr> <tr><td>Roll Diameter</td><td>125 mm</td></tr> <tr><td>Roll Width</td><td>2 x 25 mm</td></tr> <tr><td>Roll Core</td><td>3 inch = 76 mm</td></tr> <tr><td>Pre-set Length Adjustable</td><td>No</td></tr> <tr><td>Adhesive tape type</td><td>Single-Sided</td></tr> </table>	Weight	2500 g	Length/Width/Height	270/70/125 mm	Roll Diameter	125 mm	Roll Width	2 x 25 mm	Roll Core	3 inch = 76 mm	Pre-set Length Adjustable	No	Adhesive tape type	Single-Sided	 
Weight	2500 g																
Length/Width/Height	270/70/125 mm																
Roll Diameter	125 mm																
Roll Width	2 x 25 mm																
Roll Core	3 inch = 76 mm																
Pre-set Length Adjustable	No																
Adhesive tape type	Single-Sided																





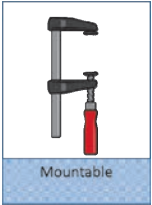
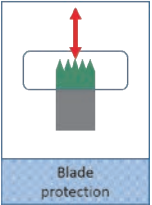
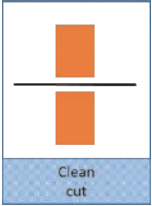

## Special Bench Dispensers

### INDUSTRIE PROFI – Manual Bench Dispenser

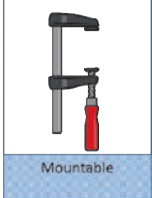
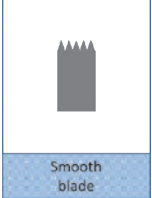
Article	Product picture	Technical data	Features														
<b>161-6080</b> <ul style="list-style-type: none"> <li>Manual bench dispenser for diverse adhesive tapes</li> <li>Brackets allow for secure bench or wall mounting</li> <li>Solid steel construction</li> <li>Simple but effective operation</li> <li>Holds up to two tape rolls of different widths</li> <li>Rounded blades for finger protection</li> <li>Optional weight plate available*</li> </ul>		<table border="1"> <tr><td>Weight</td><td>3200 g</td></tr> <tr><td>Length/Width/Height</td><td>260/320/210 mm</td></tr> <tr><td>Roll Diameter</td><td>140 mm</td></tr> <tr><td>Roll Width</td><td>1 roll: 100 mm 2 rolls: 2 x 50 mm</td></tr> <tr><td>Roll Core</td><td>3 inch = 76 mm</td></tr> <tr><td>Pre-set Length Adjustable</td><td>No</td></tr> <tr><td>Adhesive tape type</td><td>Single-Sided</td></tr> </table>	Weight	3200 g	Length/Width/Height	260/320/210 mm	Roll Diameter	140 mm	Roll Width	1 roll: 100 mm 2 rolls: 2 x 50 mm	Roll Core	3 inch = 76 mm	Pre-set Length Adjustable	No	Adhesive tape type	Single-Sided	  
Weight	3200 g																
Length/Width/Height	260/320/210 mm																
Roll Diameter	140 mm																
Roll Width	1 roll: 100 mm 2 rolls: 2 x 50 mm																
Roll Core	3 inch = 76 mm																
Pre-set Length Adjustable	No																
Adhesive tape type	Single-Sided																

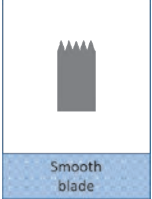
\*sold separately

## Special Bench Dispensers





Article	Product picture	Technical data	Features														
<b>tesa® 6009</b> <ul style="list-style-type: none"> <li>Special purpose bench dispenser for packaging and masking tapes</li> <li>Screw clamp allows flexible fastening of the dispenser on table edge or other surfaces</li> </ul>		<table border="1"> <tr><td>Weight</td><td>340 g</td></tr> <tr><td>Length/Width/Height</td><td>180/85/230 mm</td></tr> <tr><td>Roll Diameter</td><td>210 mm</td></tr> <tr><td>Roll Width</td><td>50 mm</td></tr> <tr><td>Roll Core</td><td>3 inch = 76 mm</td></tr> <tr><td>Pre-set Length Adjustable</td><td>No</td></tr> <tr><td>Adhesive tape type</td><td>Single-Sided</td></tr> </table>	Weight	340 g	Length/Width/Height	180/85/230 mm	Roll Diameter	210 mm	Roll Width	50 mm	Roll Core	3 inch = 76 mm	Pre-set Length Adjustable	No	Adhesive tape type	Single-Sided	 
Weight	340 g																
Length/Width/Height	180/85/230 mm																
Roll Diameter	210 mm																
Roll Width	50 mm																
Roll Core	3 inch = 76 mm																
Pre-set Length Adjustable	No																
Adhesive tape type	Single-Sided																
<b>tesa® 6012</b> <ul style="list-style-type: none"> <li>Special bench dispenser for packaging tapes</li> <li>Can be filled with either one wide roll or two narrow rolls of tape</li> <li>Can be fastened securely with the supplied clamp or with screws on the packing table</li> </ul>		<table border="1"> <tr><td>Weight</td><td>610 g</td></tr> <tr><td>Length/Width/Height</td><td>175/67/130 mm</td></tr> <tr><td>Roll Diameter</td><td>145 mm</td></tr> <tr><td>Roll Width</td><td>1 x 50 mm 2x 25 mm</td></tr> <tr><td>Roll Core</td><td>3 inch = 76 mm</td></tr> <tr><td>Pre-set Length Adjustable</td><td>No</td></tr> <tr><td>Adhesive tape type</td><td>Single-Sided</td></tr> </table>	Weight	610 g	Length/Width/Height	175/67/130 mm	Roll Diameter	145 mm	Roll Width	1 x 50 mm 2x 25 mm	Roll Core	3 inch = 76 mm	Pre-set Length Adjustable	No	Adhesive tape type	Single-Sided	  
Weight	610 g																
Length/Width/Height	175/67/130 mm																
Roll Diameter	145 mm																
Roll Width	1 x 50 mm 2x 25 mm																
Roll Core	3 inch = 76 mm																
Pre-set Length Adjustable	No																
Adhesive tape type	Single-Sided																
<b>161-6021-N</b> <ul style="list-style-type: none"> <li>Robust bench label and die-cut dispenser</li> <li>Can be filled with either one wide roll or two narrow rolls of tape</li> </ul>		<table border="1"> <tr><td>Weight</td><td>1400 g</td></tr> <tr><td>Length/Width/Height</td><td>250/150/130 mm</td></tr> <tr><td>Roll Diameter</td><td>Max. 180 mm</td></tr> <tr><td>Roll Width</td><td>Max. 100 mm</td></tr> <tr><td>Roll Core</td><td>Not relevant</td></tr> <tr><td>Pre-set Length Adjustable</td><td>No</td></tr> <tr><td>Adhesive tape type</td><td>Labels &amp; Die-cuts</td></tr> </table>	Weight	1400 g	Length/Width/Height	250/150/130 mm	Roll Diameter	Max. 180 mm	Roll Width	Max. 100 mm	Roll Core	Not relevant	Pre-set Length Adjustable	No	Adhesive tape type	Labels & Die-cuts	
Weight	1400 g																
Length/Width/Height	250/150/130 mm																
Roll Diameter	Max. 180 mm																
Roll Width	Max. 100 mm																
Roll Core	Not relevant																
Pre-set Length Adjustable	No																
Adhesive tape type	Labels & Die-cuts																

## Bag Sealing Dispensers



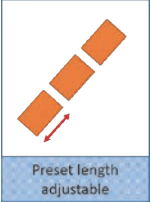
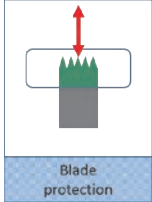

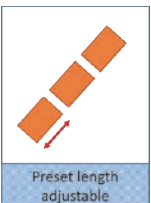
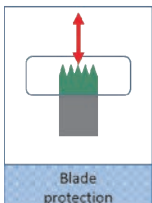

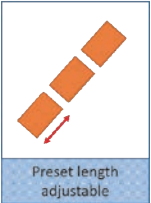
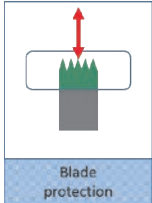
<b>tesa® 6094 L</b> <ul style="list-style-type: none"> <li>Bag sealer for medium and large sized bags up to 5 kg and 11 mm diameter</li> <li>Hidden blade (blade protection)</li> </ul>		<table border="1"> <tr><td>Weight</td><td>1350 g</td></tr> <tr><td>Length/Width/Height</td><td>210/85/205 mm</td></tr> <tr><td>Roll Diameter</td><td>170 mm</td></tr> <tr><td>Roll Width</td><td>19 mm</td></tr> <tr><td>Roll Core</td><td>3 inch = 76 mm</td></tr> <tr><td>Pre-set Length Adjustable</td><td>No</td></tr> <tr><td>Adhesive tape type</td><td>Single-Sided</td></tr> </table>	Weight	1350 g	Length/Width/Height	210/85/205 mm	Roll Diameter	170 mm	Roll Width	19 mm	Roll Core	3 inch = 76 mm	Pre-set Length Adjustable	No	Adhesive tape type	Single-Sided	 
Weight	1350 g																
Length/Width/Height	210/85/205 mm																
Roll Diameter	170 mm																
Roll Width	19 mm																
Roll Core	3 inch = 76 mm																
Pre-set Length Adjustable	No																
Adhesive tape type	Single-Sided																
<b>tesa® 6256 S</b> <ul style="list-style-type: none"> <li>Like tesa® 6094 L, yet for a diameter of 6 mm and up to 3 kg</li> <li>Hidden blade (blade protection)</li> </ul>		<table border="1"> <tr><td>Weight</td><td>610 g</td></tr> <tr><td>Length/Width/Height</td><td>185/70/270 mm</td></tr> <tr><td>Roll Diameter</td><td>130 mm</td></tr> <tr><td>Roll Width</td><td>12 mm</td></tr> <tr><td>Roll Core</td><td>3 inch = 76 mm</td></tr> <tr><td>Pre-set Length Adjustable</td><td>No</td></tr> <tr><td>Adhesive tape type</td><td>Single-Sided</td></tr> </table>	Weight	610 g	Length/Width/Height	185/70/270 mm	Roll Diameter	130 mm	Roll Width	12 mm	Roll Core	3 inch = 76 mm	Pre-set Length Adjustable	No	Adhesive tape type	Single-Sided	 
Weight	610 g																
Length/Width/Height	185/70/270 mm																
Roll Diameter	130 mm																
Roll Width	12 mm																
Roll Core	3 inch = 76 mm																
Pre-set Length Adjustable	No																
Adhesive tape type	Single-Sided																



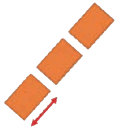



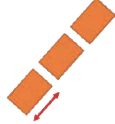

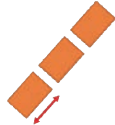



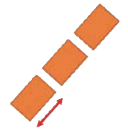

## Semi-automatic Dispensers

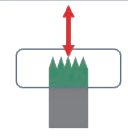
Article	Product picture	Technical data	Features															
<b>161-0237</b> <ul style="list-style-type: none"> <li>① Semi-automatic dispenser for packaging and other tapes</li> <li>① Tape is dispensed by pressing the handle</li> <li>① Adjustable pre-set tape length up to 100 mm</li> <li>① Hidden blade (blade protection)</li> </ul>		<table border="1"> <tr> <td>Weight</td> <td>1400 g</td> </tr> <tr> <td>Length/Width/Height</td> <td>200/105/125 mm</td> </tr> <tr> <td>Roll Diameter</td> <td>140 mm</td> </tr> <tr> <td>Roll Width</td> <td>25 mm</td> </tr> <tr> <td>Roll Core</td> <td>1 or 3 inch</td> </tr> <tr> <td>Pre-set Length Adjustable</td> <td>Yes</td> </tr> <tr> <td>Adhesive tape type</td> <td>Single-Sided</td> </tr> </table>	Weight	1400 g	Length/Width/Height	200/105/125 mm	Roll Diameter	140 mm	Roll Width	25 mm	Roll Core	1 or 3 inch	Pre-set Length Adjustable	Yes	Adhesive tape type	Single-Sided		
Weight	1400 g																	
Length/Width/Height	200/105/125 mm																	
Roll Diameter	140 mm																	
Roll Width	25 mm																	
Roll Core	1 or 3 inch																	
Pre-set Length Adjustable	Yes																	
Adhesive tape type	Single-Sided																	
<b>tesa® 6037</b> <ul style="list-style-type: none"> <li>① Semi-automatic dispenser for packaging and other tapes</li> <li>① Tape is dispensed by pressing the handle</li> <li>① Adjustable pre-set tape length up to 100 mm</li> <li>① Hidden blade (blade protection)</li> </ul>		<table border="1"> <tr> <td>Weight</td> <td>1400 g</td> </tr> <tr> <td>Length/Width/Height</td> <td>200/105/125 mm</td> </tr> <tr> <td>Roll Diameter</td> <td>140 mm</td> </tr> <tr> <td>Roll Width</td> <td>30 mm</td> </tr> <tr> <td>Roll Core</td> <td>3 inch = 76 mm</td> </tr> <tr> <td>Pre-set Length Adjustable</td> <td>Yes</td> </tr> <tr> <td>Adhesive tape type</td> <td>Single-Sided</td> </tr> </table>	Weight	1400 g	Length/Width/Height	200/105/125 mm	Roll Diameter	140 mm	Roll Width	30 mm	Roll Core	3 inch = 76 mm	Pre-set Length Adjustable	Yes	Adhesive tape type	Single-Sided		
Weight	1400 g																	
Length/Width/Height	200/105/125 mm																	
Roll Diameter	140 mm																	
Roll Width	30 mm																	
Roll Core	3 inch = 76 mm																	
Pre-set Length Adjustable	Yes																	
Adhesive tape type	Single-Sided																	
<b>tesa® 6038</b> <ul style="list-style-type: none"> <li>① Semi-automatic dispenser with robust metal case for packaging and other tapes</li> <li>① Tape is dispensed by pressing the handle</li> <li>① Adjustable pre-set tape length up to 100 mm, adjustable by scale</li> <li>① Non-adhesive finger lift</li> <li>① Hidden blade (blade protection)</li> </ul>		<table border="1"> <tr> <td>Weight</td> <td>2600 g</td> </tr> <tr> <td>Length/Width/Height</td> <td>270/120/175 mm</td> </tr> <tr> <td>Roll Diameter</td> <td>140 mm</td> </tr> <tr> <td>Roll Width</td> <td>30 mm</td> </tr> <tr> <td>Roll Core</td> <td>3 inch = 76 mm</td> </tr> <tr> <td>Pre-set Length Adjustable</td> <td>Yes</td> </tr> <tr> <td>Adhesive tape type</td> <td>Single-Sided</td> </tr> </table>	Weight	2600 g	Length/Width/Height	270/120/175 mm	Roll Diameter	140 mm	Roll Width	30 mm	Roll Core	3 inch = 76 mm	Pre-set Length Adjustable	Yes	Adhesive tape type	Single-Sided		
Weight	2600 g																	
Length/Width/Height	270/120/175 mm																	
Roll Diameter	140 mm																	
Roll Width	30 mm																	
Roll Core	3 inch = 76 mm																	
Pre-set Length Adjustable	Yes																	
Adhesive tape type	Single-Sided																	

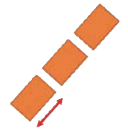

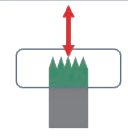

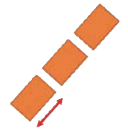

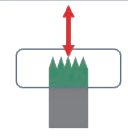



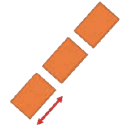

## Fully Automatic Dispensers



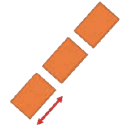



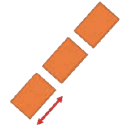



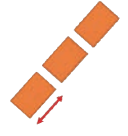

Article	Product picture	Technical data	Features															
<b>161-0259</b> <ul style="list-style-type: none"> <li>Fully automatic tape dispenser, especially for Polyimid tapes</li> <li>Pre-set tape length from 15-70 mm</li> <li>Adjustable photocell for automatic dispensing</li> </ul>		<table border="1"> <tr><td><b>Weight</b></td><td>1900 g</td></tr> <tr><td><b>Length/Width/Height</b></td><td>258/126/150 mm</td></tr> <tr><td><b>Roll Diameter</b></td><td>150 mm</td></tr> <tr><td><b>Roll Width</b></td><td>3-25 mm</td></tr> <tr><td><b>Roll Core</b></td><td>Not relevant</td></tr> <tr><td><b>Pre-set Length Adjustable</b></td><td>Yes</td></tr> <tr><td><b>Adhesive tape type</b></td><td>Single-Sided</td></tr> </table>	<b>Weight</b>	1900 g	<b>Length/Width/Height</b>	258/126/150 mm	<b>Roll Diameter</b>	150 mm	<b>Roll Width</b>	3-25 mm	<b>Roll Core</b>	Not relevant	<b>Pre-set Length Adjustable</b>	Yes	<b>Adhesive tape type</b>	Single-Sided	 Preset length adjustable	 Electrical
<b>Weight</b>	1900 g																	
<b>Length/Width/Height</b>	258/126/150 mm																	
<b>Roll Diameter</b>	150 mm																	
<b>Roll Width</b>	3-25 mm																	
<b>Roll Core</b>	Not relevant																	
<b>Pre-set Length Adjustable</b>	Yes																	
<b>Adhesive tape type</b>	Single-Sided																	
<b>161-0256</b> <ul style="list-style-type: none"> <li>Fully automatic tape dispenser</li> <li>Digital Display of the Pre-set length</li> <li>Pre-set tape length from 20-998 mm</li> <li>Photocell for automatic dispensing</li> <li>Integrated safety guard mechanism</li> </ul>		<table border="1"> <tr><td><b>Weight</b></td><td>2400 g</td></tr> <tr><td><b>Length/Width/Height</b></td><td>218/137/150 mm</td></tr> <tr><td><b>Roll Diameter</b></td><td>180 mm</td></tr> <tr><td><b>Roll Width</b></td><td>7-50 mm</td></tr> <tr><td><b>Roll Core</b></td><td>3 inch = 76 mm</td></tr> <tr><td><b>Pre-set Length Adjustable</b></td><td>Yes</td></tr> <tr><td><b>Adhesive tape type</b></td><td>Single &amp; Double-Sided</td></tr> </table>	<b>Weight</b>	2400 g	<b>Length/Width/Height</b>	218/137/150 mm	<b>Roll Diameter</b>	180 mm	<b>Roll Width</b>	7-50 mm	<b>Roll Core</b>	3 inch = 76 mm	<b>Pre-set Length Adjustable</b>	Yes	<b>Adhesive tape type</b>	Single & Double-Sided	 Counter	 Preset length adjustable
<b>Weight</b>	2400 g																	
<b>Length/Width/Height</b>	218/137/150 mm																	
<b>Roll Diameter</b>	180 mm																	
<b>Roll Width</b>	7-50 mm																	
<b>Roll Core</b>	3 inch = 76 mm																	
<b>Pre-set Length Adjustable</b>	Yes																	
<b>Adhesive tape type</b>	Single & Double-Sided																	
<b>161-0269</b> <ul style="list-style-type: none"> <li>Fully automatic tape dispenser</li> <li>Digital Display</li> <li>Memory function stores up to 6 different pre-set lengths</li> <li>Pre-set tape length from 5-999 mm</li> <li>Photocell for automatic dispensing</li> <li>No core holder permits usage of varying core diameters</li> <li>Automatically stops if tape feed is impaired</li> <li>Custom coated main roller available for special applications</li> </ul>		<table border="1"> <tr><td><b>Weight</b></td><td>1600 g</td></tr> <tr><td><b>Length/Width/Height</b></td><td>213/116/140 mm</td></tr> <tr><td><b>Roll Diameter</b></td><td>300 mm</td></tr> <tr><td><b>Roll Width</b></td><td>6-60 mm</td></tr> <tr><td><b>Roll Core</b></td><td>Not relevant</td></tr> <tr><td><b>Pre-set Length Adjustable</b></td><td>Yes</td></tr> <tr><td><b>Adhesive tape type</b></td><td>Single &amp; Double-Sided</td></tr> </table>	<b>Weight</b>	1600 g	<b>Length/Width/Height</b>	213/116/140 mm	<b>Roll Diameter</b>	300 mm	<b>Roll Width</b>	6-60 mm	<b>Roll Core</b>	Not relevant	<b>Pre-set Length Adjustable</b>	Yes	<b>Adhesive tape type</b>	Single & Double-Sided	 Counter	 Preset length adjustable
<b>Weight</b>	1600 g																	
<b>Length/Width/Height</b>	213/116/140 mm																	
<b>Roll Diameter</b>	300 mm																	
<b>Roll Width</b>	6-60 mm																	
<b>Roll Core</b>	Not relevant																	
<b>Pre-set Length Adjustable</b>	Yes																	
<b>Adhesive tape type</b>	Single & Double-Sided																	



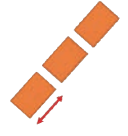



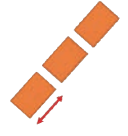







## Fully Automatic Dispensers















Article	Product picture	Technical data	Futures																		
<b>161-0269-F</b> <ul style="list-style-type: none"> <li>Equivalent to 161-0269</li> <li>Non-adhesive finger lift</li> </ul>		<table border="1"> <tr> <td>Weight</td> <td>1830 g</td> </tr> <tr> <td>Length/Width/Height</td> <td>222/116/148 mm</td> </tr> <tr> <td>Roll Diameter</td> <td>300 mm</td> </tr> <tr> <td>Roll Width</td> <td>6-60 mm</td> </tr> <tr> <td>Roll Core</td> <td>Not relevant</td> </tr> <tr> <td>Pre-set Length Adjustable</td> <td>Yes</td> </tr> <tr> <td>Adhesive tape type</td> <td>Single &amp; Double-Sided</td> </tr> </table>	Weight	1830 g	Length/Width/Height	222/116/148 mm	Roll Diameter	300 mm	Roll Width	6-60 mm	Roll Core	Not relevant	Pre-set Length Adjustable	Yes	Adhesive tape type	Single & Double-Sided	<table border="1"> <tr> <td>             Counter         </td> <td>             Preset length adjustable         </td> </tr> <tr> <td>             Electrical         </td> <td>             Blade protection         </td> </tr> </table>	 Counter	 Preset length adjustable	 Electrical	 Blade protection
Weight	1830 g																				
Length/Width/Height	222/116/148 mm																				
Roll Diameter	300 mm																				
Roll Width	6-60 mm																				
Roll Core	Not relevant																				
Pre-set Length Adjustable	Yes																				
Adhesive tape type	Single & Double-Sided																				
 Counter	 Preset length adjustable																				
 Electrical	 Blade protection																				

## Fully Automatic Label & Die-Cut Dispensers

Article	Product picture	Technical data	Futures																		
<b>161-0622-120</b> <ul style="list-style-type: none"> <li>Fully automatic label and die-cut dispenser</li> <li>Photocell for automatic dispensing</li> <li>The speed of the Pre-set length can be adjusted</li> <li>Incorporated counter</li> <li>Release paper rewind</li> <li>Identically constructed dispenser for tapes in:                70 mm Width: 161-0622-70                160 mm Width: 161-0622-160                200 mm Width: 161-0622-200             </li> </ul>		<table border="1"> <tr> <td>Weight</td> <td>2900 g</td> </tr> <tr> <td>Length/Width/Height</td> <td>200/180/210 mm</td> </tr> <tr> <td>Roll Diameter</td> <td>210 mm</td> </tr> <tr> <td>Roll Width</td> <td>20-120 mm</td> </tr> <tr> <td>Roll Core</td> <td>Not relevant</td> </tr> <tr> <td>Pre-set Length Adjustable</td> <td>Yes</td> </tr> <tr> <td>Adhesive tape type</td> <td>Label &amp; Die-cut</td> </tr> </table>	Weight	2900 g	Length/Width/Height	200/180/210 mm	Roll Diameter	210 mm	Roll Width	20-120 mm	Roll Core	Not relevant	Pre-set Length Adjustable	Yes	Adhesive tape type	Label & Die-cut	<table border="1"> <tr> <td>             Counter         </td> <td>             Preset length adjustable         </td> </tr> <tr> <td>             Electrical         </td> <td>             Without blade         </td> </tr> </table>	 Counter	 Preset length adjustable	 Electrical	 Without blade
Weight	2900 g																				
Length/Width/Height	200/180/210 mm																				
Roll Diameter	210 mm																				
Roll Width	20-120 mm																				
Roll Core	Not relevant																				
Pre-set Length Adjustable	Yes																				
Adhesive tape type	Label & Die-cut																				
 Counter	 Preset length adjustable																				
 Electrical	 Without blade																				

<b>161-0624-120</b> <ul style="list-style-type: none"> <li>Fully automatic label and die-cut dispenser</li> <li>Adjustable photocell for automatic dispensing</li> <li>Distance and speed of label advancement is adjustable</li> <li>Incorporated counter</li> <li>Release paper rewind</li> <li>Identically constructed dispenser for tapes in:                60 mm Width: 161-0624-60                180 mm Width: 161-0624-180             </li> </ul>		<table border="1"> <tr> <td>Weight</td> <td>3300 g</td> </tr> <tr> <td>Length/Width/Height</td> <td>231/164/157 mm</td> </tr> <tr> <td>Roll Diameter</td> <td>250 mm</td> </tr> <tr> <td>Roll Width</td> <td>20-120 mm</td> </tr> <tr> <td>Roll Core</td> <td>Not relevant</td> </tr> <tr> <td>Pre-set Length Adjustable</td> <td>Yes</td> </tr> <tr> <td>Adhesive tape type</td> <td>Labels &amp; Die-cuts</td> </tr> </table>	Weight	3300 g	Length/Width/Height	231/164/157 mm	Roll Diameter	250 mm	Roll Width	20-120 mm	Roll Core	Not relevant	Pre-set Length Adjustable	Yes	Adhesive tape type	Labels & Die-cuts	<table border="1"> <tr> <td>             Counter         </td> <td>             Preset length adjustable         </td> </tr> <tr> <td>             Electrical         </td> <td>             Without blade         </td> </tr> </table>	 Counter	 Preset length adjustable	 Electrical	 Without blade
Weight	3300 g																				
Length/Width/Height	231/164/157 mm																				
Roll Diameter	250 mm																				
Roll Width	20-120 mm																				
Roll Core	Not relevant																				
Pre-set Length Adjustable	Yes																				
Adhesive tape type	Labels & Die-cuts																				
 Counter	 Preset length adjustable																				
 Electrical	 Without blade																				

Product	Type	Weight in g	Length in mm	Width in mm	Height in mm	Max. Roll Diameter in mm	Max. Roll Width in mm	Roll Core in inch $\phi$	Pre-set Length Adjustable	Adhesive Tape Type	Page
<b>Hand Dispensers</b>											
 161-21401	Profi	410	205	40	210	170	25	3	No	Single-Sided	4
 161-21402	Profi	520	220	65	210	170	50	3	No	Single-Sided	4
 161-21403	Profi	700	215	90	210	170	75	3	No	Single-Sided	4
 505008	Classic	625	180	70	250	136	50	3	No	Single-Sided	5
 505009	Classic	785	180	100	250	136	75	3	No	Single-Sided	5
 161-4200	Classic	500	180	60	230	140	50	3	No	Single-Sided	5
 6300	Classic	350	150	65	240	120	50	3	No	Single-Sided	5
 6400	Classic	500	220	60	220	140	50	3	No	Single-Sided	5
 161-0213	Special	330	150	25	210	150	25	3	No	Double-Sided	6
 6032	Special	335	220	45	80	150	25	3	No	Single-Sided	6
 6076	Special	500	165	60	130	120	50	3	No	Single-Sided	6
 161-0276-50	Special	480	165	55	125	110	50	3	No	Single-Sided	6
<b>Bench Dispensers</b>											
 161-0257	Classic	1280	220	79	90	110	25	1 or 3	No	Single-Sided	7
 57422	Classic	2000	230	70	130	110	25	3	No	Single-Sided	7
 6090	Classic	2500	270	70	125	125	2 x 25	3	No	Single-Sided	7

Product	Type	Weight in g	Length in mm	Width in mm	Height in mm	Max. Roll Diameter in mm	Max. Roll Width in mm	Roll Core in inch $\phi$	Pre-set Length Adjustable	Adhesive Tape Type	Page
<b>Bench Dispensers</b>											
 161-6080	Profi	3200	260	320	210	140	1 x 100 2 x 50	3	No	Single-Sided	7
 6009	Special	340	180	85	230	210	50	3	No	Single-Sided	8
 6012	Special	610	175	67	130	145	1 x 50 2 x 25	3	No	Single-Sided	8
 161-6021-N	Special	1400	250	150	130	180	100	Not relevant	No	Labels & Die-cuts	8
<b>Bag Sealing Dispensers</b>											
 6094 L	Classic	1350	210	85	205	170	19	3	No	Single-Sided	8
 6256 S	Classic	610	185	70	270	130	12	3	No	Single-Sided	8
<b>Automatic Dispensers</b>											
 161-0237	Semi-automatic	1400	200	105	125	140	25	1 oder 3	Yes	Single-Sided	9
 6037	Semi-automatic	1400	200	105	125	140	30	3	Yes	Single-Sided	9
 6038	Semi-automatic	2600	270	120	175	140	30	3	Yes	Single-Sided	9
 161-0259	Fully automatic	1900	258	126	150	150	3-25	Not relevant	Yes	Single & Double-Sided	10
 161-0256	Fully automatic	2400	218	137	150	180	7-50	3	Yes	Single & Double-Sided	10
 161-0269	Fully automatic	1600	213	116	140	300	6-60	Not relevant	Yes	Single & Double-Sided	10
 161-0269-F	Fully automatic	1830	222	116	148	300	6-60	Not relevant	Yes	Single & Double-Sided	10
 161-0622-120	Fully automatic	2900	200	190	180	210	20-120	Not relevant	Yes	Labels & Die-cuts	11
 161-0624-120	Fully automatic	3300	231	164	157	250	20-120	Not relevant	Yes	Label & Die-cuts	11



## Accessories

### Product picture

### Description



#### Dispenser Mounting Plate with Tape Holder

- Allows the tape roll to be secured on the dispenser mounting plate
- For rolls with a max. 320 mm external diameter
- Suitable for: 161-0256, 161-0269 and 161-0269-F



#### Elevated Dispenser Holder with Tape Holder

- Dispenser holder with adjustable slant
- For rolls with a max. 320 mm external diameter
- Suitable for: 161-0256, 161-0269 and 161-0269-F



#### Dispenser Mounting Plate with Rewind Option

- Automatic rewind of the release liner
- Suitable for: 161-0256, 161-0269 and 161-0269-F



#### Elevated Dispenser Mounting Plate with Rewind Option

- Adjustable slant
- For max. 150 mm external roll diameter
- Automatic rewind of the release liner
- Suitable for: 161-0256, 161-0269 and 161-0269-F

• **Further Accessories Upon Request** •

For Further Information Please See Our Other Catalogs

Check out our other catalogs: **Adhesive Tapes for Electrical Insulation, Double-Sided Adhesive Tapes, Acrylic Foam Tapes and Adhesive Foam Tapes (volzMoll)**. These catalogs provide an in-depth overview about the chosen product group and detailed information regarding applications, product features and more.

Call or see us online to request a catalog today.

### Adhesive Tapes for Electrical Insulation

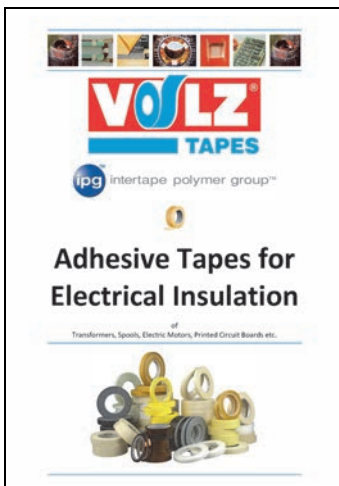

### Double-Sided Adhesive Tapes

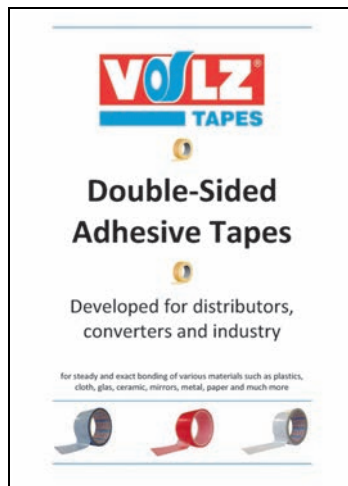

### Acrylic Foam Tapes



### Adhesive Foam Tapes



## Notes

---



---



---



---



---



---



---



---



---



---



---



---



---



---



---



---



---



---



---



---



---



---



---



---



---



---



---



---